

CATÁLOGO
CATALOGUE
CATALOG

2026-2027



FEPRE[®]



Estimado Cliente,



En **FEPRE** entendemos que el mercado evoluciona constantemente y que los profesionales necesitan cada vez más **surtidos eficientes, productos innovadores y proveedores fiables**.

Por eso trabajamos cada día para ofrecer soluciones que aporten valor real al punto de venta: productos competitivos, implantaciones rentables y un servicio cercano y especializado.

Nuestro equipo está formado por profesionales con una amplia experiencia en el sector, lo que nos permite conocer de primera mano las necesidades del mercado y desarrollar propuestas adaptadas a los canales de distribución más exigentes de Europa.

El resultado de este trabajo es el nuevo **Catálogo General Fepre 2026-2027**, una herramienta pensada para facilitar la selección de producto y ayudarle a construir surtidos equilibrados, competitivos y preparados para las necesidades actuales del consumidor.

En este catálogo encontrará:

- Un **amplio surtido de productos** para ferretería y bricolaje.
- **Nuevas referencias y mejoras de gama**.
- Propuestas de **implantación adaptadas a diferentes tipos de negocio**.
- Soluciones diseñadas para **optimizar el espacio de venta y mejorar la rentabilidad**.

Sabemos que **cada establecimiento es único**. Por ello hemos desarrollado diferentes conceptos de colección que encontrará al final de cada apartado, pensados para adaptarse a distintos espacios y necesidades de venta.

Además, si nos facilita las medidas de su espacio y sus necesidades comerciales, nuestro equipo podrá elaborar un **planograma totalmente personalizado**, optimizando el surtido y la implantación para aprovechar al máximo su superficie de venta.

Seguiremos trabajando con un objetivo claro:

ayudarle a que su negocio disponga siempre de los mejores productos, con la máxima competitividad y el mejor servicio.

Cher Client,



Chez **FEPRE**, nous comprenons que le marché évolue constamment et que les professionnels ont de plus en plus besoin **d'assortiments efficaces, de produits innovants et de fournisseurs fiables**.

C'est pourquoi nous travaillons chaque jour pour offrir des solutions qui apportent une réelle valeur au point de vente : produits compétitifs, implantations rentables et un service proche et spécialisé.

Notre équipe est composée de professionnels ayant une vaste expérience dans le secteur, ce qui nous permet de connaître de première main les besoins du marché et de développer des propositions adaptées aux canaux de distribution les plus exigeants d'Europe.

Le résultat de ce travail est le nouveau **Catalogue Général Fepre 2026-2027**, un outil conçu pour faciliter la sélection des produits et vous aider à construire des assortiments équilibrés, compétitifs et préparés aux besoins actuels du consommateur.

Dans ce catalogue, vous trouverez :

- Une **large gamme de produits** pour la quincaillerie et le bricolage.
- **Nouvelles références et améliorations des gammes**.
- Des propositions de **mise en œuvre adaptées à différents types d'activités**.
- Des solutions conçues pour **optimiser l'espace de vente et améliorer la rentabilité**.

Nous savons que **chaque établissement est unique**. C'est pourquoi nous avons développé différents concepts de collection que vous trouverez à la fin de chaque section, conçus pour s'adapter aux différents espaces et besoins de vente.

De plus, si vous nous fournissez les mesures de votre espace et vos besoins commerciaux, notre équipe pourra élaborer un **planogramme entièrement personnalisé**, en optimisant l'assortiment et l'implantation pour tirer le meilleur parti de votre surface de vente.

Nous continuerons à travailler avec un objectif clair :

vous aider à ce que votre entreprise dispose toujours des meilleurs produits, avec la compétitivité maximale et le meilleur service.

Dear Customer,



At **FEPRE** we understand that the market is constantly evolving and that professionals need increasingly efficient **assortments, innovative products and reliable suppliers**.

That's why we work every day to offer solutions that bring real value to the point of sale: competitive products, profitable implementations and a close and specialized service.

Our team is made up of professionals with extensive experience in the sector, which allows us to know at first hand the market needs and develop proposals adapted to the most demanding distribution channels in Europe.

The result of this work is the new **Fepre 2026-2027 General Catalog**, a tool designed to facilitate product selection and help you build balanced, competitive assortments prepared for current consumer needs.

In this catalogue you will find:

- A **wide range of hardware and DIY products**.
- **New references and range improvements**.
- Implementation **proposals adapted to different types of business**.
- Solutions designed to **optimize sales space and improve profitability**.

We know that **every establishment is unique**. That is why we have developed different collection concepts that you will find at the end of each section, designed to adapt to different spaces and sales needs.

In addition, if you provide us with the measurements of your space and your commercial needs, our team will be able to **prepare a fully personalized planogram**, optimizing the assortment and implementation to make the most of your sales area.

We will continue to work with a clear goal: help your business to always have the best products, with maximum competitiveness and the best service.



COMPANY WITH
QUALITY SYSTEM
ISO 9001

Eduardo Coloma
Director General / Directeur Général
General Manager



Esquema-guía para la interpretación de este catálogo
 Schéma-guide pour l'interprétation du catalogue
 Scheme-guide to the interpretation of this catalogue



CUADRADAS | CARRÉES | SQUARE

Reforzadas con borde · Renforcées avec cadre
 Reinforced whit edging

Subcategoría
 Sous-catégorie
 Subcategory

Descripción del artículo
 Description article
 Item description

Color / Acabado
 Couleur / fini
 Colour / Finished

Referencia
 Référence
 Reference

				ALU
15 x 15	55 x 11	10 y 12	47	8421272

Imágenes del producto

Image du Produit
 Product Pictures

Características técnicas

Caractéristiques techniques
 Technical characteristics

Información sobre la presentación del producto

Information sur la présentation des produits
 Information about product presentation

Información sobre prestaciones del producto

Information sur les prestations du produit
 Product benefits information



NOVEDAD EN ESTE CATÁLOGO · NOUVEAU DANS CE CATALOGUE
 NEW IN THIS CATALOG

009973

Nuevos productos catálogo 2026
 Catalogue des nouveaux produits 2026
 New products catalog 2026

NOVEDAD EN ESTE CATÁLOGO · NOUVEAU DANS CE CATALOGUE
 NEW IN THIS CATALOG

009973

Producto incluido en el expositor JUNIOR
 Produit inclus dans le présentoir JUNIOR
 Product included in the JUNIOR display



Esquema-guía para la interpretación de la tarifa | Schéma-guide pour l'interprétation de la tarif
 Scheme-guide to the interpretation of list price

Rejillas de aluminio e inox con mosquitera
 Grilles alu et inox avec moustiquaire
 Aluminium and stainless steel grilles

Familia de productos

Famille produit
 Product family

Página de publicación del producto

Page de publication du produit
 Product publication page

EAN = 8421272 + Ref.

Unidades de venta en embalaje primario

Unités de vente sur l'emballage primaire
 Product benefits information

PAG	REF	EAN	UE
PAG 25	051235	8421272051235	5

Referencia publicada en el catálogo

Référence publié dans le catalogue
 Reference published in the catalog

Estructura del catálogo por apartados y productos

Structure du catalogue par sections et produits
Catalog structure by sections and products

VENTILACIÓN
VENTILATION
VENTILATION

PAGS 10-60

ORDENACIÓN
AMÉNAGEMENT
ORGANISATION

PAGS 61-92

HOGAR
MAISON
HOME

PAGS 93-130

Pictogramas de información sobre la presentación del producto

Pictogrammes d'information sur la présentation des produits
Information pictograms about product presentation



Unidad de embalaje
Unités d'emballage
Packing



Colgador incluido
Crochet inclus
Hanger included



Presentación en bolsa
Présenté en sac
Bag pack presentation



Presentación retractilado
Présenté sous film plastique
Shrink-wrapped presentation



Incluye código EAN
Inclut code EAN
Includes EAN code



Presentación en blister
Présenté en blister
Blister pack presentation



Cantoneras de protección incluidas
Coins de protection compris
Protective corner including

Pictogramas de información sobre las prestaciones del producto

Pictogrammes d'information sur les prestations du produit
Information pictograms about product performances



Con mosquitera protectora de insectos
Avec moustiquaire protecteur d'insectes
With protective insects net



Incluye tornillos de instalación
Comprend les vis de montage
Includes mounting screws



Eje de orientación horizontal
Orientation de l'axe horizontal
Horizontal orientation axis



Montaje de superficie
Montage de surface
Surface Mount



Modelo standard
Modèle standard
Standard model



Doble eje de orientación horizontal
Double orientation de l'axe horizontal
Double axis horizontal orientation



Montaje empotrable
Montage a encastrer
Flush mounting



Modelo por cuerda
Modèle de corde
Rope model



Triple eje de orientación horizontal
Triple axe d'orientation horizontal
Triple axis horizontal orientation



Montaje empotrable con clips
montage a encastrer avec clips
Built-in mounting with clips



Controlador de humedad
Capteur d'humidité
Humidity sensor



Giro de orientación de 360°
Virement d'orientation de 360°
360° Rotation



Paso de aire regulable
Débit d'air réglable
Adjustable airflow



Temporizador
Temporisateur
Timer



Nivelación horizontal
Alignement horizontal
Horizontal alignment



Caudal de aire
Flux d'air
Airflow



Válvula antiretorno
Clapet anti-retour
Any return valve



Inclinable
Basculant
Tilted



Montaje mediante adhesivo
Montage avec adhésif
Assembly using glue



Orientación vertical
Réglage vertical
Vertical orientation



Articulado
Articulée
Articulated



Montaje mediante tornillos
Montage avec vis
Screw mounting



Brazo extensible
Bras extensible
Extensible



Extensible
Extensible
Extensible



Cocina
Cuisine
Kitchen



Sanitario
Sanitaire
Sanitary



Expositor junior
Expositeur junior
Junior display



CALIDAD, SERVICIO Y SOSTENIBILIDAD

En 1.969, **Fepre** impulsa el mercado del bricolaje con una clara vocación: ofrecer productos fiables, servicio ágil y una relación de confianza duradera con nuestros clientes. Más de cinco décadas de trayectoria nos han permitido consolidarnos como un socio de referencia para las principales cuentas del sector, tanto en el mercado nacional como europeo.

Nuestra sede central en Rubí (Barcelona) junto con nuestra plataforma logística en Castellbisbal (Barcelona), con más de 7.000 m², integra una moderna planta de producción totalmente automatizada, diseñada para garantizar la máxima eficiencia, calidad constante y capacidad de respuesta ante las necesidades del mercado.

Comprometidos con un modelo empresarial responsable, hemos incorporado en nuestras instalaciones un sistema de generación de energía mediante placas fotovoltaicas para autoconsumo. Esta inversión representa un paso firme en nuestra estrategia de sostenibilidad y en la reducción de nuestro impacto ambiental. Al mismo tiempo estamos ya fabricando todas nuestras rejillas tanto de aluminio como de ABS utilizando materias primas 100% recicladas y transformando paulatinamente los embalajes de plástico a cartón con certificación FSC

En Fepre entendemos que crecer también significa cuidar del entorno. Por ello, trabajamos continuamente para optimizar nuestros procesos, mejorar la eficiencia energética y promover iniciativas que contribuyan activamente a la protección del planeta.

Innovación, eficiencia y sostenibilidad forman parte de nuestra manera de entender el presente y de construir el futuro.



QUALITÉ, SERVICE ET SOUTENABILITÉ

En 1969, **Fepre** développe le marché du bricolage avec une vocation claire : offrir des produits fiables, un service agile et une relation de confiance durable avec nos clients. Plus de cinq décennies de trajectoire nous ont permis de nous consolider comme un partenaire de référence pour les principaux comptes du secteur, tant sur le marché national qu'europpéen.

Notre siège central à Rubí (Barcelone) ainsi que notre plateforme logistique à Castellbisbal (Barcelone), avec plus de 7.000 m², intègre une usine de production moderne entièrement automatisée, conçue pour garantir une efficacité maximale, qualité constante et capacité de réponse aux besoins du marché.

Engagés dans un modèle d'entreprise responsable, nous avons intégré à nos installations un système de production d'énergie utilisant des plaques photovoltaïques pour l'autoconsommation. Cet investissement représente un pas en avant dans notre stratégie de durabilité et dans la réduction de notre impact environnemental. Dans le même temps, nous fabriquons déjà toutes nos grilles en aluminium et en ABS à partir de matières premières 100% recyclées et transformons progressivement les emballages plastiques en carton certifié FSC

Chez Fepre, nous comprenons que grandir signifie aussi prendre soin de l'environnement. C'est pourquoi nous travaillons sans relâche pour optimiser nos processus, améliorer l'efficacité énergétique et promouvoir des initiatives qui contribuent activement à la protection de la planète. L'innovation, l'efficacité et la durabilité font partie de notre manière de comprendre le présent et de construire l'avenir.

QUALITY, SERVICE AND SUSTAINABILITY

In 1969 **Fepre** drives the DIY market with a clear vocation: to offer reliable products, agile service and a lasting relationship of trust with our customers. More than five decades of experience have allowed us to consolidate as a reference partner for the main accounts of the sector, both in the national and European market.

Our headquarters in Rubí (Barcelona) together with our logistics platform in Castellbisbal (Barcelona), with more than 7,000 m², integrates a modern fully automated production plant, designed to ensure maximum efficiency, consistent quality and responsiveness to market needs.

Committed to a responsible business model, we have incorporated into our facilities an energy generation system using photovoltaic panels for self-consumption. This investment represents a firm step in our sustainability strategy and in reducing our environmental impact. At the same time, we are already manufacturing all our aluminum and ABS grids using 100% recycled raw materials and gradually transforming plastic packaging into FSC-certified cardboard

At Fepre we understand that growing up also means taking care of the environment. That's why we are continuously working to optimize our processes, improve energy efficiency and promote initiatives that actively contribute to the protection of the planet.

Innovation, efficiency and sustainability are part of how we understand the present and build the future.



PRESENCIA EN FERIAS Y SALONES

Durante años hemos participado en las Ferias más importantes del Sector del Bricolaje, como la International Hardware en Colonia, National Hardware Show en Las Vegas, Brico & Habitat International Exhibition en París, International Trade Fair en Dubai, Eurobrico Meeting Point en Valencia o Ferroforma International Exhibition en Bilbao, donde pudimos contactar directamente con Distribuidores y Grandes Cuentas de todo el mundo.

PRÉSENCE EN FOIRES ET SALONS

Pendant des années, nous avons participé à des foires les plus importantes du secteur du bricolage, comme le salon international de la quincaillerie à Cologne, le salon national de la quincaillerie à Las Vegas, le salon international Brico & Habitat à Paris, la foire internationale de Dubaï, le point de rencontre Eurobrico à Valence ou le salon international Ferroforma à Bilbao, où nous avons pu contacter directement avec Distributeurs et les Grands Comptes de toute le monde.

FEPRE AT TRADE FAIRS AND EVENTS

For years we have participated in the most important fairs of the DIY sector, such as the International Hardware Show in Cologne, National Hardware Show in Las Vegas, Brico & Habitat International Exhibition in Paris, International Trade Fair in Dubai, Eurobrico Meeting Point in Valencia or Ferroforma International Exhibition in Bilbao, where we could contact directly with distributors and Large Account worldwide.





FEPRE EN LOS MERCADOS DEL BRICOLAJE INTERNACIONAL

FEPRE SUR LES MARCHÉS INTERNATIONAUX DU BRICOLAGE

FEPRE ON THE INTERNATIONAL DIY MARKETS

VENTILACIÓN | VENTILATION | VENTILATION



ORDENACIÓN | AMÉNAGEMENT | ORGANISATION



HOGAR | MAISON | HOME



VENTILACIÓN VENTILATION VENTILATION VENTILATION

REJILLAS DE VENTILACIÓN

GRILLES D'AÉRATION

VENTILATION GRILLES

- 12** **Rejillas de aluminio** | Grilles en alu | Aluminium grilles
- 17** **Rejillas reforzadas** | Grilles renforcées | Reinforced grilles
- 22** **Luxair**
- 23** **Rejillas con copa y difusores** | Grilles avec dôme et diffuseurs | Grilles with dome and diffusers
- 25** **Entradas de aire** | Entrées d'air | Window and door ventilation
- 26** **Rejillas de ABS** | Grilles ABS | ABS grilles
- 36** **Aeroventiladores de función mecánica** | Aérateurs a lamelles | Mechanical air ventilators

EXTRACTORES Y ACCESORIOS DE EXTRACCIÓN

EXTRACTEURS ET ACCESSOIRES D'AÉRATION

EXTRACTORS AND VENTILATION ACCESSORIES

- 37** **Extractores** | Extracteurs | Extractors
- 43** **Accesorios para extractores** | Accessoires d'extraction | Accessories for extractors
- 44** **Accesorios para conectividad de tubos** | Accessoires de connectivité | Accessories for duct connection
- 46** **Tubos y accesorios para conectividad. PVC** | Tubes et accessoires de connectivité | Pipes and accessories for connectivity. PVC

EXPOSITORES/IMPLANTACIONES

EXPOSITEURS/IMPLANTATIONS

DISPLAYS AND IN-STORE CONCESSIONS

- 50** **Rejillas de ventilación** | Grilles d'aération | Ventilation grilles
- 55** **Extractores, tubos y accesorios** | Extracteurs, tubs et accessoires | Extractors piping and accessories



COMPANY WITH
QUALITY SYSTEM
ISO 9001

MEDIDAS REJILLAS DE ALUMINIO CUADRADAS Y RECTANGULARES
DIMENSIONS GRILLES EN ALUMINIUM CARRÉES ET RECTANGULAIRES
SQUARE AND RECTANGULAR ALUMINUM GRIDS



5x15 cm



5x25 cm



5x40 cm



10x10 cm



10x20 cm



10x30 cm



15x15 cm

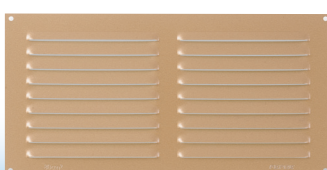

15x30 cm

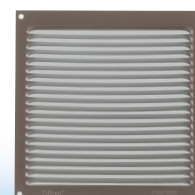

17x17 cm



20x10 cm

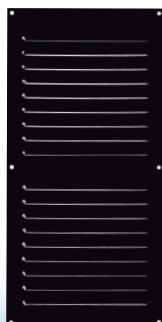

30x15 cm

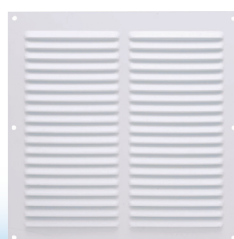

20x20 cm



20x30 cm



20x40 cm



25x25 cm



30x30 cm

Rejillas de aluminio sin mosquitera y sin gancho

Grilles alu sans moustiquaire ni crochet

Aluminium grilles without net or hook

EAN = 8421272 + Ref.

CUADRADAS | CARRÉES | SQUARE



A x B cm ²	Material	Thickness (mm)										
		0,6	0,8	0,6	0,8	0,8	0,8	0,8	0,6	0,6	0,8	0,8
		ALU	ALU	Bianco Blanc White	Bianco Blanc White	Plata mate Argent mat Matt Silver	Oro Or Gold	Bronce Bronze Bronze	Haya Hêtre Beech	Wenge	Negro Noire Black	Antracita Anthracite Anthracite
10 x 10	25	053303	053563	053433	053693	053822		054089	054218		056205	058568
15 x 15	66	053334	053594	053464	053723	053853	053983	054119	054249	054379	056229	058599
17 x 17	150	053358	053617	053488	053747	053877	054003	054133	054263	054393	056243	058612
20 x 20	95	053372	053631	053501	053761	053891	054027	054157	054287		056250	058636
25 x 25	150	053402	053662	053532	053792	053921					054676	058667
30 x 30	240	053426	053686	053556	053815	053945					054690	058681



RECTANGULARES | RECTANGULAIRES | RECTANGULARS



A x B cm ²	Material	Thickness (mm)									
		0,6	0,8	0,6	0,8	0,8	0,8	0,8	0,6	0,8	0,8
		ALU	ALU	Bianco Blanc White	Bianco Blanc White	Plata mate Argent mat Matt Silver	Oro Or Gold	Bronce Bronze Bronze	Haya Hêtre Beech	Negro Noire Black	Antracita Anthracite Anthracite
10 x 20	50	053310	053570	053440	053709	053839		054096	054225	056212	058575
20 x 10v	50	053365	053624	053495	053754	053884					
10 x 30	72	053327	053587	053457	053716	053846				054614	058582
20 x 30	150	053389	053648	053518	053778	053907				054652	058643
20 x 40	200	053396	053655	053525	053785	053914				054669	058650
15 x 30	80	053341	053600	053471	053730	053860	053990	054126		056236	058605
30 x 15v	80	053419	053679	053549	053808	053938					



Rejillas de aluminio sin mosquitera y con gancho
 Grilles en aluminium sans moustiquaire et avec crochet
 Aluminium grilles without net and with hook



EAN = 8421272 + Ref.

CUADRADAS | CARRÉES | SQUARE



A x B cm	A x B cm ²	0,6		0,8		0,6		0,8		0,8		0,8		0,6		0,6		0,8		0,8	
		ALU	ALU	Bianco Blanc White	Bianco Blanc White	Plata mate Argent mat Matt Silver	Oro Or Gold	Bronce Bronze Bronze	Haya Hêtre Beech	Wenge	Negro Noir Black	Antracita Anthracite Anthracite									
10 x 10	25	001502	001625	001403	002349	001748				001984	002585	008471	003650	058704							
15 x 15	66	001571	001694	001472	002417	001816	001939	002059	002653	008549	003674	058735									
17 x 17	150	001601	001724	001397	002448	001847	001960	002080	006484	008594	003698	058759									
20 x 20	95	001540	001663	001441	002387	001786	001908	002028	002622		003704	058773									
25 x 25	150	002479	002950	002462	002967	002974					003742	058803									
30 x 30	240	001618	001731	001359	002455	001854					003766	058827									



RECTANGULARES | RECTANGULAIRES | RECTANGULARS



A x B cm	A x B cm ²	0,6		0,8		0,6		0,8		0,8		0,8		0,6		0,6		0,8		0,8	
		ALU	ALU	Bianco Blanc White	Bianco Blanc White	Plata mate Argent mat Matt Silver	Oro Or Gold	Bronce Bronze Bronze	Haya Hêtre Beech	Wenge	Negro Noir Black	Antracita Anthracite Anthracite									
10 x 20	50	001519	001632	001410	002356	001755				001991	002592	008488	003667	058711							
20 x 10v	50	001526	001649	001427	002363	001762															
10 x 30	72	001533	001656	001434	002370	001779							003643	058728							
20 x 30	150	001557	001670	001458	002394	001793							003728	058780							
20 x 40	200	001564	001687	001465	002400	001809							003735	058797							
15 x 30	80	001588	001700	001489	002424	001823	001946	002066					003681	058742							
30 x 15v	80	001595	001717	001496	002431	001830															



Rejillas de aluminio e inox con mosquitera sin gancho
 Grilles alu et inox avec moustiquaire sans crochet
 Aluminium and stainless steel grilles with net without hook



EAN = 8421272 + Ref.

CUADRADAS | CARRÉES | SQUARE



A x B cm ²	ALU	ALU	Blanco Blanc White	Blanco Blanc White	Plata mate Argent mat Matt Silver	Oro Or Gold	Bronce Bronze Bronze	Haya Hêtre Beech	Wenge	INOX SUS 430	Negro Noire Black	Antracita Anthracite Anthracite	0,6	0,8	0,6	0,8	0,8	0,8	0,6	0,6	0,5	0,8	0,8	
10 x 10	25	054706	054966	054836	055123	055284		055604	055765		056052	058117	058841											
15 x 15	66	054737	054997	054867	055154	055314	055475	055635	055796	055956	056083	058148	058872											
17 x 17	150	054751	055017	054881	055178	055338	055499	055659	055819	055970	056120	058162	058896											
20 x 20	95	054775	055031	054904	055192	055352	055512	055673	055833		056106	058186	058919											
25 x 25	150	054805	055062	054935	055222	055383						058216	058940											
30 x 30	240	054829	055086	054959	055246	055406						058230	058964											



RECTANGULARES | RECTANGULAIRES | RECTANGULARS



A x B cm ²	ALU	ALU	Blanco Blanc White	Blanco Blanc White	Plata mate Argent mat Matt Silver	Oro Or Gold	Bronce Bronze Bronze	Haya Hêtre Beech	Wenge	INOX SUS 430	Negro Noire Black	Antracita Anthracite Anthracite	0,6	0,8	0,6	0,8	0,8	0,8	0,6	0,6	0,5	0,8	0,8	
5 x 15	13				055093	055253	055413	055574	055734	055895														
5 x 25	25				055109	055260		055581																
5 x 40	42				055116	055277																		
10 x 20	50	054713	054973	054843	055130	055291		055611	055772		056069	058124	058858											
20 x 10v	50	054768	055024	054898	055185	055345																		
10 x 30	72	054720	054980	054850	055147	055307						058131	058865											
20 x 30	150	054782	055048	054911	055208	055369						058193	058926											
20 x 40	200	054799	055055	054928	055215	055376						058209	058933											
15 x 30	80	054744	055000	054874	055161	055321	055482					058155	058889											
30 x 15v	80	054812	055079	054942	055239	055390																		



PACK 30 REJILLAS | PACK 30 GRILLES | PACK 30 GRILLES



A x B	cm ²	0,6
15 x 15	66	Blanco Blanc White
20 x 20	95	005715
		005708



Rejillas de aluminio con mosquitera y gancho
 Grilles alu et inox avec moustiquaire et crochet
 Aluminium and stainless steel grilles with net and hook



EAN = 8421272 + Ref.

CUADRADAS | CARRÉES | SQUARE



		0,6	0,8	0,6	0,8	0,8	0,8	0,8	0,6	0,6	0,5	0,8	0,8
A x B	cm	ALU	ALU	Blanco Blanc White	Blanco Blanc White	Plata mate Argent mat Matt Silver	Oro Or Gold	Bronce Bronze Bronze	Haya Hêtre Beech	Wenge	INOX SUS 430	Negro Noire Black	Antracita Anthracite Anthracite
A x B	cm ²												
10 x 10	25	008204	003773	005869	002714	002103		002837	003896		040471	008334	058988
15 x 15	66	008273	003841	005937	002783	002172	002295	002905	003964	008693	040495	008365	059015
17 x 17	150	008303	003872	005968	002813	002202	002325	002936	002523	008730	041553	008389	059039
20 x 20	95	008242	003810	005906	002752	002141	002264	002875	003933		040488	008402	059053
25 x 25	150	008310	002493	005975	002509	002554					041546	008433	059084
30 x 30	240	008327	003889	005982	002820	002219						008457	059107



RECTANGULARES | RECTANGULAIRES | RECTANGULARS



		0,6	0,8	0,6	0,8	0,8	0,8	0,8	0,6	0,6	0,5	0,8	0,8
A x B	cm	ALU	ALU	Blanco Blanc White	Blanco Blanc White	Plata mate Argent mat Matt Silver	Oro Or Gold	Bronce Bronze Bronze	Haya Hêtre Beech	Wenge	INOX SUS 430	Negro Noire Black	Antracita Anthracite Anthracite
A x B	cm ²												
5 x 15	13				040259	040068	040310	040112	041584	041560			
5 x 25	25				040266	040075		040129					
5 x 40	42				040273	040082							
10 x 20	50	008211	003780	005876	002721	002110		002844	003902		040525	008341	058995
20 x 10v	50	008228	003797	005883	002738	002127							
10 x 30	72	008235	003803	005890	002745	002134						008358	059008
20 x 30	150	008259	003827	005913	002769	002158						008419	059060
20 x 40	200	008266	003834	005920	002776	002165						008426	059077
15 x 30	80	008280	003858	005944	002790	002189	002301	002912				008372	059022
30 x 15v	80	008297	003865	005951	002806	002196							



Rejillas de aluminio con mosquitera y gancho
 Grilles alu et inox avec moustiquaire et crochet
 Aluminium and stainless steel grilles with net and hook



EAN = 8421272 + Ref.

STRONG | STRONG | STRONG



A x B	cm²	Blanco/Blanc/White	Antracita/Anthracite	Arena/Sable/Sand
15 x 15	36	003322	003384	003353
20 X 20	69	003346	003407	



FUSION | FUSION | FUSION (ABS +ALU)



A x B	cm²	Blanco/Blanc/White	Negro/Inox/Black/Inox	Negro/Roble/Noir/Chêne/Black/Oak
17 X 17	51	047982	048019	048040



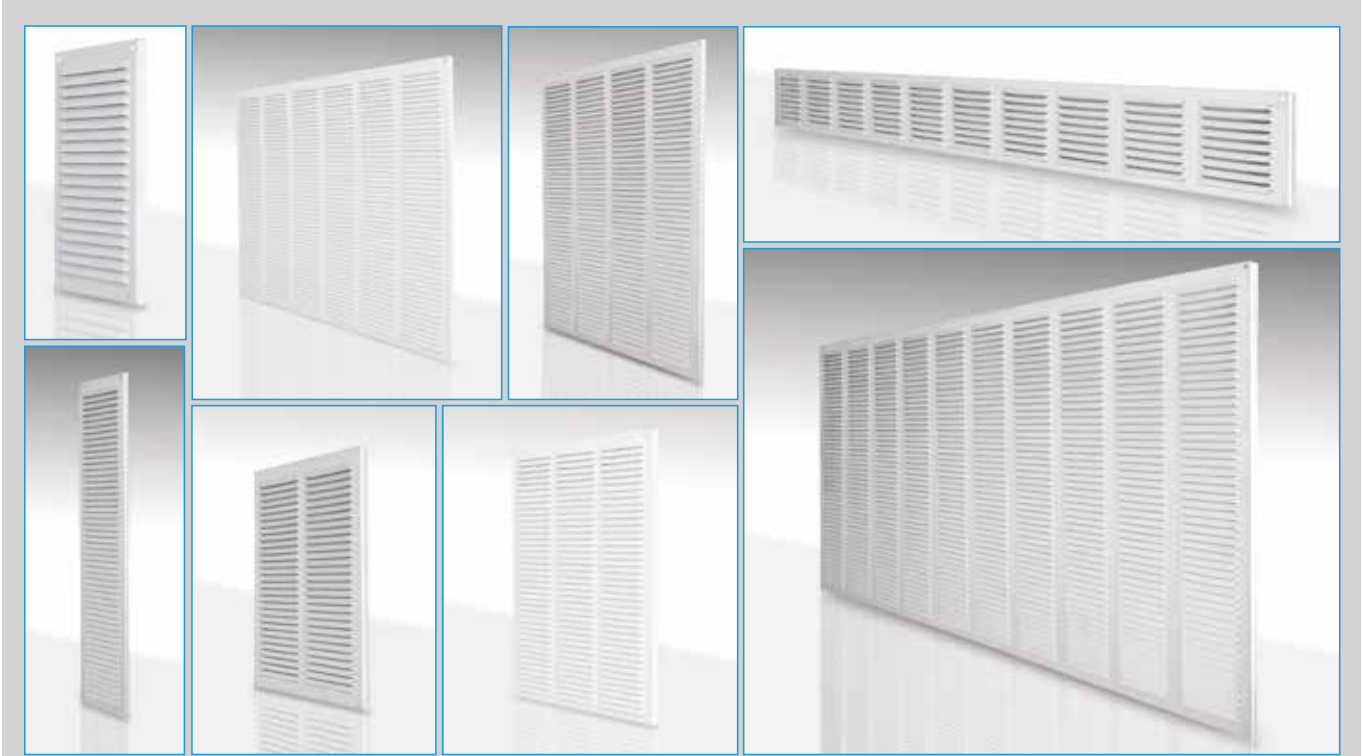

Rejillas reforzadas de alta calidad, con material promocional para tu punto de venta.
 Grilles renforcées haute qualité, avec matériel promotionnel pour votre point de vente.
 High-quality reinforced grilles with promotional material for your point of sale

REJILLAS REFORZADAS CON Y SIN BORDE
 GRILLES RENFORCÉES AVEC ET SANS BORDURE
 GRIDS REINFORCED WITH AND WITHOUT BORDER



CARTEL GRATUITO 102 x 52 cm • PANNEAU GRATUITE 102 x 52 cm • FREE PANEL 102 x 52 cm

Rejillas de aluminio
Grilles en alu
Aluminium grilles



CARTEL GRATUITO 102 x 52 cm
PANNEAU GRATUITE 102 x 52 cm
FREE PANEL 102 x 52 cm



EAN = 8421272 + Ref.

REFORZADAS CON BORDE | RENFORCÉES AVEC CADRE | REINFORCED WITH EDGING

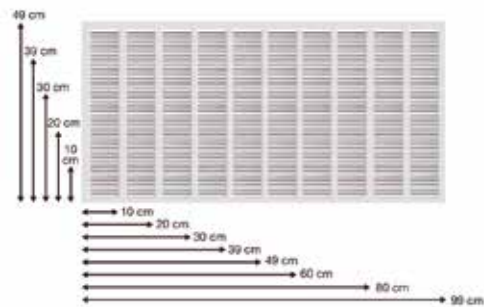

SERIE 10

A x B		cm	1,5	1,5
A x B		cm ²	ALU	Blanco Blanc White
10 x 10	17	007108	007207	
10 x 20	34	007115	007214	
10 x 30	51	007122	007221	
10 x 39	68	007139	007238	
10 x 49	85	007146	007245	
10 x 60	103	007153	007252	
10 x 80	137	007160	007269	
10 x 99	171	007177	007276	



SERIE 20

A x B		cm	1,5	1,5
A x B		cm ²	ALU	Blanco Blanc White
20 x 10	36	007900	008006	
20 x 20	72	007917	008013	
20 x 30	108	007924	008020	
20 x 39	144	007931	008037	
20 x 49	180	007948	008044	
20 x 60	217	007955	008051	
20 x 80	289	007962	008068	
20 x 99	361	007979	008075	



PARA PISCINAS, SALA DE MÁQUINAS, GIMNASIOS, GARAJES Y SOTANOS.
POUR LES PISCINES, LES SALLES DE MACHINES, LES GYMNASES,
LES GARAGES ET LES SOUS-SOLS.
FOR SWIMMING POOLS, MACHINE ROOMS, GYMS, GARAGES AND BASEMENTS.

SERIE 30

A x B		cm	1,5	1,5
A x B		cm ²	ALU	Blanco Blanc White
30 x 10	55	007702	007801	
30 x 20	110	007719	007818	
30 x 30	165	007726	007825	
30 x 39	220	007733	007832	
30 x 49	275	007740	007849	
30 x 60	331	007757	007856	
30 x 80	441	007764	007863	
30 x 99	551	007771	007870	



SERIE 39

A x B		cm	1,5	1,5
A x B		cm ²	ALU	Blanco Blanc White
39 x 10	76	007504	007603	
39 x 20	152	007511	007610	
39 x 30	228	007528	007627	
39 x 39	304	007535	007634	
39 x 49	380	007542	007641	
39 x 60	456	007559	007658	
39 x 80	608	007566	007665	
39 x 99	760	007573	007672	



SERIE 49

A x B		cm	1,5	1,5
A x B		cm ²	ALU	Blanco Blanc White
49 x 10	97	007009	007405	
49 x 20	194	007016	007412	
49 x 30	291	007023	007429	
49 x 39	388	007030	007436	
49 x 49	484	007047	007443	
49 x 60	581	007054	007450	
49 x 80	775	007061	007467	
49 x 99	969	007078	007474	



- Fabricación sobre pedido. Consultar plazo de entrega. Gran capacidad de paso de aire. Especial para garajes, salas de máquinas, sótanos.
- Fabrication sur commande. Demander le délais de livraison. Grande capacité de passage d'air. Spécial pour les garages, les salles de machines, caves.
- Manufactured to order. Check delivery terms. Large capacity air flow. Purpose-built for garage, machinery rooms, basement.

Rejillas de aluminio
Grilles en alu
Aluminium grilles



CARTEL GRATUITO 102 x 52 cm
PANNEAU GRATUITE 102 x 52 cm
FREE PANEL 102 x 52 cm



EAN = 8421272 + Ref.

REFORZADAS SIN BORDE | RENFORCÉES SANS CADRE |
REINFORCED WITHOUT EDGING



Sin mosquitera | Sans moustiquaire |
Without net

A x B cm	cm ²	1,5			
		ALU	Blanco Blanc White	Negro Noire Black	Antracita Anthracite Anthraxite
20 x 25	108	028462	028547	028301	028141
30 x 25	162	028479	028554	028325	028165
40 x 25	243	028486	028561	028349	028189
50 x 25	297	028493	028578	028363	028202
20 x 50	216	028509	028585	028318	028158
30 x 50	324	028516	028592	028332	028172
40 x 50	487	028523	028608	028356	028196
50 x 50	595	028530	028615	028370	028219



Con mosquitera | Avec moustiquaire |
With net

A x B cm	cm ²	1,5			
		ALU	Blanco Blanc White	Negro Noire Black	Antracita Anthracite Anthraxite
20 x 25	108	028622	028707	028387	028226
30 x 25	162	028639	028714	028400	028240
40 x 25	243	028646	028721	028424	028264
50 x 25	297	028653	028738	028448	028288
20 x 50	216	028660	028745	028394	028233
30 x 50	324	028677	028752	028417	028257
40 x 50	487	028684	028769	028431	028271
50 x 50	595	028691	028776	028455	028295



- Gran capacidad de paso de aire. Especial para garajes, salas de máquinas, sótanos.
- Grande capacité de passage d'air. Spécial pour les garages, les salles de machines, caves.
- Check delivery terms. arge capacity air flow. Purpose-built for garage, machinery rooms, basement.

Rejillas de aluminio
Grilles en alu
Aluminium grilles



EAN = 8421272 + Ref.

EMPOTRABLES | Á ENCASTRER | BUILT-IN



A x B	A x B	mm	0,6	0,8	0,6	0,8	0,8
17 x 16,5	14,2 x 15	150	ALU	ALU	Blanco Blanc White	Blanco Blanc White	Plata mate Argent mat Matt Silver
22 x 11,5	19x10	49		004015		004213	004060
22 x 21,5	19 x 20	95		004022		004220	004077



- Entran a presión. No necesitan tornillos.
- Sous pression. Sans Vis.
- Pressure inserted. No screws required.

DECOR | DECOR | DECOR



A x B	A x B	mm	1,5	1,5	1,5	1,5
8 x 30	6,6 x 28	68	Blanco Blanc White	Plata mate Argent mat Matt Silver	Negro Noir Black	Antracita Anthracite Anthracite
8 x 50	6,6 x 48	117	028813	028790	028875	028899



- Rejilla decorativa para microondas, hornos empotrados, frigoríficos, etc. Entran a presión. No necesitan tornillos.
- Grille Déco spéciale micro-ondes, fours encastrés, réfrigérateurs, etc. Sous pression. Sans Vis.

DECOR VINTAGE | DECOR VINTAGE



A x B	A x B	mm	1,5	1,5
8 x 30	6,6 x 28	43	Blanco Blanc White	Plata mate Argent mat Matt Silver
			046510	046534



- Rejilla decorativa para microondas, hornos empotrados, frigoríficos, etc. Entran a presión. No necesitan tornillos.
- Grille Déco spéciale micro-ondes, fours encastrés, réfrigérateurs, etc. Sous pression. Sans Vis.
- Decorative grille for microwaves, built-in ovens, fridges, etc. Pressure inserted. No screws required.

Rejillas de aluminio
Grilles en alu
Aluminium grilles



EAN = 8421272 + Ref.

REGULABLES | RÉGLABLE | ADJUSTABLE

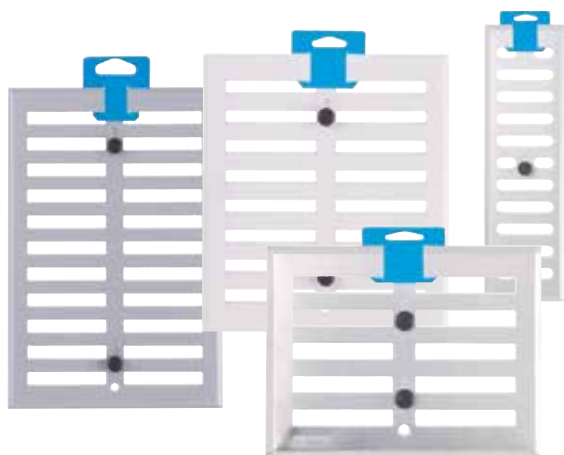

A x B cm	cm ²	0,8		
		ALU	Blanco Blanc White	Plata mate Argent mat Matt Silver
4'5 x 24	0 - 18		040297	040099
7 x 24	0 - 39		040303	040105
17 x 13	0 - 56	004510	004718	004565
17 x 19	0 - 89	004527	004725	004572
17 x 25	0 - 123	004534	004732	004589



- Alta precisión de regulación.
- Haute précision de régulation.
- Highly accurate adjusting.
- Elevata precisione di regolazione.

EMPOTRABLES A TUBO | ENCASTRER À TUBE | BUILT-IN TUBE MOUNTED



FALTA IMG
MOSQUETERA
TRASERA

Standard

A Ø cm	B Ø cm	cm ²	ALU	Blanco Blanc White	Blanco Blanc White Blanco
10	8	18	040396	040389	
12	10	30	040419	040402	027021
15	12	50	040433	040426	027038



Regulable | Réglable | Adjustable

A Ø cm	B Ø cm	cm ²	Blanco Blanc White	Negro Noire Black	Antracita Anthracite
12	10	0 - 14	041676	041683	041768
14	12	0 - 26	041690	041706	041775



MALLA MOSQUITERA | MOUSTIQUAIRE | ANTI-INSECT NET



Dim.	
50 x 100 cm	014489
100 x 100 cm	014496
160 cm x 30 m	014502



- Malla mosquitera de fibra de vidrio. Presentación en rollo.
- Moustiquaire fiberglass. En rouleau..
- Mesh fiberglass insect screen. Presentation roll.

Rejillas de aluminio
Grilles en alu
Aluminium grilles

EAN = 8421272 + Ref.

LUXAIR EVO BY FEPRE. Rejillas a medida | Grilles a mesure | Grilles to measure

Fácil, rápido, económico y con diseño propio | Facile, rapide, économique et avec design propre
Easy, quick, affordable and with your own design

SOBREPONER · SUPERPOSER · MOUNTED

A nivel de superficie
À niveau de surface
At surface level

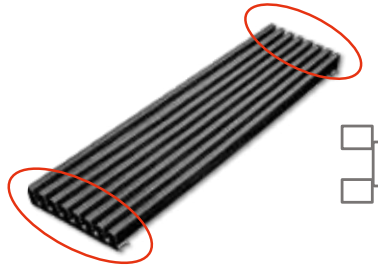

Mira el video.
Voir le vidéo.
Watch the video.

CÁLCULO DEL PASO DE AIRE

Con esta sencilla fórmula puede calcular el paso de aire de la rejilla:

Anchura en cm rejilla x 0.2*
x (número de láminas - 1)
= cm² Paso de Aire

ejemplo:

60 cm 1 _____
 2 _____
60 x 0.2 x 4 3 _____
 4 _____
 5 _____
=48 cm² Paso Aire ←→
*espacio entre láminas

CALCUL DU DÉBIT D'AIR

À l'aide d'une simple formule perme de calculer le débit d'air de la grille:

Largeur en cm de grille x 0.2*
x (nombre de lames - 1)
= cm² Débit d'Air

example:

60 cm 1 _____
 2 _____
60 x 0.2 x 4 3 _____
 4 _____
 5 _____
=48 cm² Débit d'Air ←→
*écart entre lamelles

CALCULATING THE AIR PASSAGE

Using a simple formula can calculate the airflow grille as you designed:

Width in cm of the grating x 0.2*
x (number of blades - 1)
= cm² Air Pass

example:

60 cm 1 _____
 2 _____
60 x 0.2 x 4 3 _____
 4 _____
 5 _____
=48 cm² Air Pass ←→
*gap between slats

Kit de nevera. 8 lamas más terminales
Kit réfrigérateur. 8 lames plus terminaux
Fridge kit. 8 slats plus terminals



		Blanco Blanc White	INOX
8	59,5 x 11,8 x 1,9	047869	047876

- 2 terminales de empotrar y 8 lamas de 60 cm.
- 2 bornes à encastrer et 8 lamelles de 60 cm.
- 2 terminals to embedded and 8 sheets of 60 cm.



Kit para horno | Kit Four | Oven Kit

		Blanco Blanc White	Plata mate Argent mat Matt Silver	Negro Noire Black	INOX
8	59,5 x 11,8 x 1,9	046862	046886	046879	046893

- 2 terminales de sobreponer y 8 lamas de 60 cm.
- 2 bornes à surface et 8 lamelles de 60 cm.
- 2 terminals to mounted and 8 sheets of 60 cm.



Rejillas con copa
Grilles avec dôme
Grilles with dome



EAN = 8421272 + Ref.



Copas decorativas para puntos de suministro o sistemas de ventilación de escape en edificios particulares, públicos o industriales.

Bouches et diffuseurs décoratifs pour points d'alimentation ou systèmes de ventilation par extraction dans les bâtiments privés, publics ou industriels.

Decorative nozzles and diffusers for supply points or exhaust ventilation systems in private, public or industrial buildings.

PARA ATORNILLAR | À VISSER | TO BE SCREWED IN

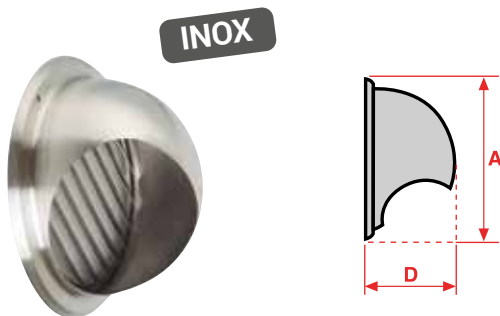

A	D	Ø ext. mm	cm ²	INOX
212	106	215	75	024242



- Alta calidad de fabricación. SUS 304. Acabado inox natural barnizado.
- Fabrication de haute qualité: SUS 304. Finition inox naturel vernie.
- High manufacturing quality: SUS 304. Lacquered natural stainless steel finish.

EMPOTRABLES | À ENCASTRER | BUILT-IN

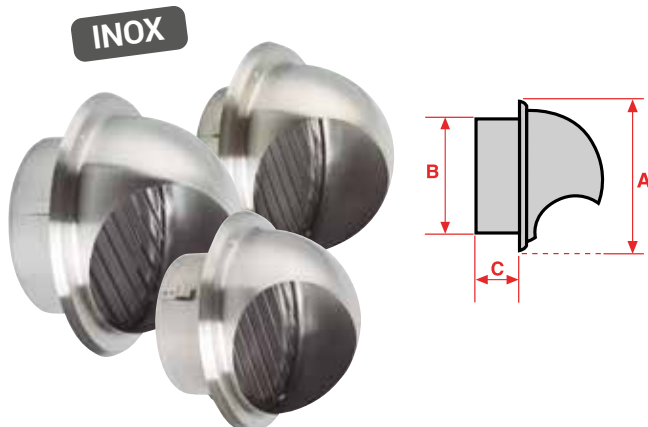

A	B	C	Ø tub. mm	cm ²	INOX
149	97	52	100	25	024020
189	120	52	125	42	024037
212	144	62	150	63	024044



- Alta calidad de fabricación. SUS 304. Acabado inox natural barnizado.
- Fabrication de haute qualité: SUS 304. Finition inox naturel vernie.
- High manufacturing quality: SUS 304. Lacquered natural stainless steel finish.

Difusores
Bouches
Diffusers



EAN = 8421272 + Ref.

PARA EMPOTRAR. Regulables | À ENCASTRER. Régables
BUILT-IN. Adjustable

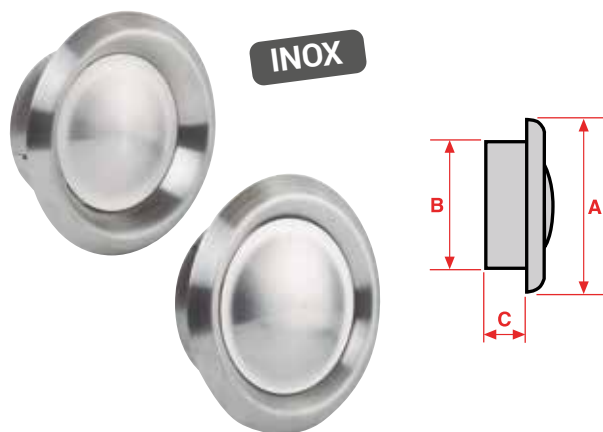

INOX

A	B	C	cm ²	INOX.
138	97	45	0-27	024204
178	120	45	0-71	024211



- Alta calidad de fabricación. SUS 304. Acabado inox natural barnizado. CON REGULACIÓN DEL CAUDAL DE AIRE.
- Fabrication de haute qualité: SUS 304. Finition inox naturel vernie. CONTRÔLE D'AIR.
- High manufacturing quality: SUS 304. Lacquered natural stainless steel finish. WITH ADJUSTABLE AIR FLOW.

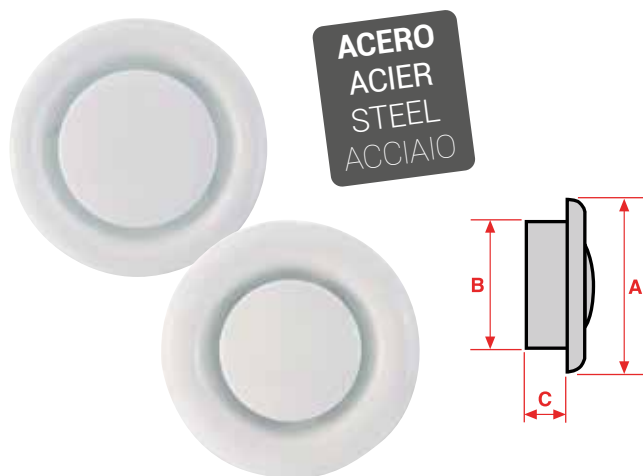

Acero | Acier | Steel

A	B	C	cm ²	Blanco Blanc White Bianco
160	97	45	0-22	024228
200	120	45	0-39	024235



- CON REGULACIÓN DEL CAUDAL DE AIRE.
- FCONTRÔLE D'AIR.
- WITH ADJUSTABLE AIR FLOW.

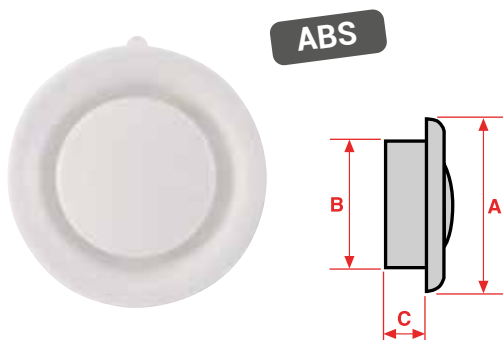

ABS

Ø cm	Ø cm	cm ²	Blanco Blanc White Bianco
13,8	10	0 - 42	041492
14,5	12	0 - 42	041508



- CON REGULACIÓN DEL CAUDAL DE AIRE.
- FCONTRÔLE D'AIR.
- WITH ADJUSTABLE AIR FLOW.

Entradas de aire para puertas y ventanas con aditivo antivioleta
 Entrées d'air pour portes et fenêtres avec un additif anti-violette
 Air inlets for windows and doors with anti-violet additive



EAN = 8421272 + Ref.

ABS



-34 dB(A)





Caudal regulable | Débit réglable
 Adjustable flow

 A x B x C	 A x B	 m³/hora	Blanco Blanc White	Marrón Marron Brown	Antracita Anthracite Anthracite
2,3 x 29,5 x 2	1,5 x 23,5	15-22-30	041195	041201	041300



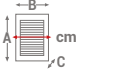
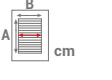

Caudal regulable y reducción acústica
 Débit réglable et réduction acoustique
 Adjustable flow and acoustic reduction

 A x B x C	 A x B	 m³/hora	Blanco Blanc White	Marrón Marron Brown
4,5 x 40,2 x 3,7	1,6 x 29,5	15-22-30	041218	041225



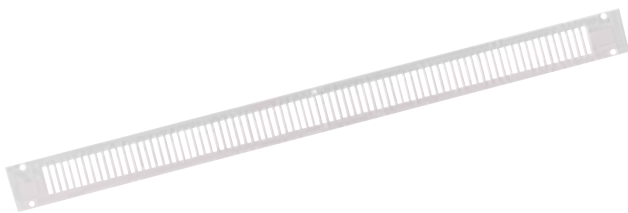

ALU ANODIZADO | ALU ANODISÉ | ANODIZED ALU





 A x B	 cm²	Plata mate Argent mat Matt Silver
2,1 x 28,5	20	041232



 A x B	 cm²	Plata mate Argent mat Matt Silver
2,8 x 29,7	23	041249



Regulable | Réglable | Adjustable

 A x B	 cm²	Plata mate Argent mat Matt Silver
2,2 x 27,5	0 - 11	041256



Rejillas de ABS
Grilles en ABS
ABS Grilles



EAN = 8421272 + Ref.

PARA ATORNILLAR | À VISSER | TO BE SCREWED IN



		Blanco Blanc White Bianco
6,4	19	040921
5		

		Blanco Blanc White Bianco
10,3	16	040938
5		

Extraplana | Extra-plate | Extra slim

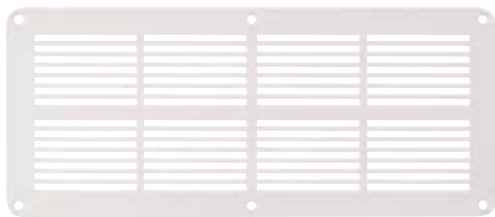

		Blanco Blanc White Bianco
11 x 25,5	92	040617
13,1 x 33,7	170	040754
5		

Con remarco | Double cadre | With remarked



		Blanco Blanc White
9 x 26	52	040631
16,5 x 26	78	040716
24 x 26	99	040891
5		

Anti-lluvia | Anti-pluie | Rain-proof



		Blanco Blanc White	
14,6 x 17,5	74	041188	027083
5			

Rejillas de ABS
Grilles en ABS
ABS Grilles



EAN = 8421272 + Ref.

PARA ATORNILLAR | À VISSER | TO BE SCREWED IN



		Blanco Blanc White
A x B	cm²	
8,6 x 16,5	25	040570

REGULABLES | RÉGLABLE | ADJUSTABLE



Regulable anti-lluvia | Réglable anti-pluie
Adjustable rain-proof

		Blanco Blanc White
A x B	cm²	
14,6 x 17,5	0-86	040648

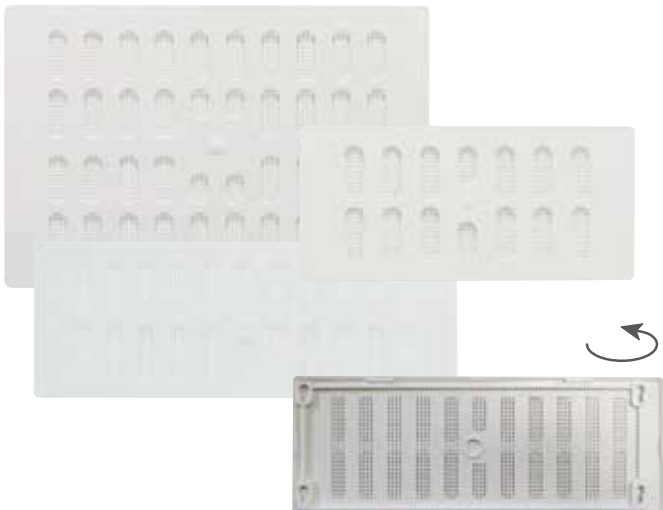

Regulable plana | Réglable plate
Adjustable slim

		Blanco Blanc White
A x B	cm²	
9,1 x 19,3	0 - 5	040587
10,7 x 28,4	0 - 16	040624
19,3 x 28,9	0 - 19	040709

Rejillas de ABS
Grilles en ABS
ABS Grilles



COMPATIBLES CON PLADUR
COMPATIBLE AVEC LES PLAQUES DE PLÂTRE
COMPATIBLE WITH PLASTERBOARD



EAN = 8421272 + Ref.

EMPOTRABLES | ENCASTRER | BUILT-IN



 Ø cm	 Ø cm	 cm ²	Blanco Blanc White
4	3,2	2,3/un.	040914





Estándar | Standard | Standard

 Ø cm	 Ø cm	 cm ²	Blanco Blanc White	Arena Sable Sand	 Blanco Blanc White	Antracita Anthracite
9,8	7,6	11	040945			
12	9,4	26	040952	041065	027045	041744
15	11,8	34	040969	041171	027052	041751
19	15,2	53	041034			





Regulable | Réglable | Adjustable

 Ø cm	 Ø cm	 cm ²	Blanco Blanc White
9,8	7,6	0 - 11	041096
12	9,4	0 - 21	041102
15	11,8	0 - 30	041119
19	15,2	0 - 56	041126



Estándar | Standard | Standard

 A x B cm	 A x B cm	 cm ²	Blanco Blanc White
14 x 14	10 x 10	36	040822



Rejillas de ABS
Grilles en ABS
ABS Grilles

COMPATIBLES CON PLADUR
COMPATIBLE AVEC LES PLAQUES DE PLÂTRE
COMPATIBLE WITH PLASTERBOARD





EAN = 8421272 + Ref.

EMPOTRABLES | ENCASTRER | BUILT-IN





Con Patillas de Encastre
Avec pattes d'encastrement
With lock-in pins

 A x B cm	 A x B cm	 cm ²	Blanco Blanc White
12 x 12	10 x 10	50	040815





Regulable | Réglable | Adjustable

 A x B cm	 A x B cm	 cm ²	Blanco Blanc White
14 x 14	10 x 10	0 - 22	040839





Estándar | Standard | Standard

 A x B cm	 A x B cm	 cm ²	Blanco Blanc White
10,7 x 25,7	8,5 x 23	62	040600
13 x 37	9,5 x 33,3	110	040761
23 x 38	18,6 x 33,4	198	040785



Premontada con marco | Pré-assemblé avec cadre
Pre-assembled with frame

 A x B cm	 cm ²	Gris Gris Gray
20 x 20	114	082150
20 x 30	145	082167
20 x 20		082174
20 x 30		082181



Rejillas de ABS
Grilles en ABS
ABS Grilles



COMPATIBLES CON PLADUR
COMPATIBLE AVEC LES PLAQUES DE PLÂTRE
COMPATIBLE WITH PLASTERBOARD



EAN = 8421272 + Ref.



EMPOTRABLES | ENCASTRER | BUILT-IN

Opción atornillar | Option visser
Screw-in option

 A x B cm	 A x B cm	 cm ²	Blanco Blanc White
8 x 16,4	6,1 x 13	35	040563
10,2 x 22,1	7,8 x 17,9	65	040594
12,9 x 25,1	10,7 x 21	105	040686
15,2 x 27,6	13 x 23,6	141	040723





Estrechos | Etroites | Slim

 A x B cm	 A x B cm	 cm ²	Blanco Blanc White
6 x 30,5	4 x 28,3	40	040730
6 x 51,5	4 x 49,7	74	040808





Doble cara puertas | Double face spécial portes
Double-sided to door

 A x B cm	 A x B cm	 cm ²	Blanco Blanc White Blanco
9 x 45	7,6 x 43	189	040792



- Tornillos incluidos.
- Visserie fournie.
- Screws included.

Multirregulable | Multi-réglable | Multi-adjustable

 A x B cm	 A x B cm	 cm ²	Blanco Blanc White
14,6 x 25	11,9 x 22,4	0 - 52	040693



Rejillas de ABS
Grilles en ABS
ABS Grilles



EAN = 8421272 + Ref.

EMPOTRABLES | ENCASTRER | BUILT-IN



Kit rejilla + Tubo telescópico + Válvula antirretorno
Kit traverse mural avec grille, tube et clapet anti retour
Grille kit + telescopic duct + non-return valve

A x B cm	Ø cm	cm ²	Long. Tubo cm	Blanco Blanc White
15 x 15	10	0 - 36	18 - 35	041461



Kit rejilla + Tubo con aletas de encastrado
Bouche d'extraction VMC
Grille kit + duct with locking-in flaps

A x B cm	Ø cm	cm ²	Blanco Blanc White
10,5 x 12,6	8	30	041478
16 x 19	12	85	041485



Prolipileno
Polypropylène
Polypropylene

Shun

A x B cm	A x B cm	cm ²	Blanco Blanc White	Blanco Blanc White
26 x 13,3	22 x 9,5	121	020107	027007



Schun Reguable | Réglable | Adjustable

A x B cm	A x B cm	cm ²	Blanco Blanc White	Blanco Blanc White
26 x 13,3	22 x 9,5	0 - 89	020121	027014



Rejillas de ABS
Grilles en ABS
ABS Grilles



EAN = 8421272 + Ref.

EMPOTRABLES A TUBO | ENCASTRER A TUBE | FOR BUILT-IN TUBE MOUNTING



Lamas móviles | Lames mobiles | Mobile slats

A x B	A x B	Ø cm	cm ²	Blanco Blanc White	027090
-------	-------	------	-----------------	--------------------------	--------

14,5 x 14	5,5 x 11	10	0 - 67	028844	
15 x 15	5,5 x 11	10 - 12	0 - 47	041423	027090
16,5 x 18,5	7,5 x 15	-	0 - 97	028851	
16,5 x 18,5	-	12	0 - 97	028837	
18,5 x 18,5	-	15	0 - 148	041669	



- Permeten la salida de aire pero no su entrada.
- Permet la sortie d'air, mais non son entrée.
- Air can go out but not in.

A x B	A x B	Ø cm	cm ²	Blanco Blanc White
-------	-------	------	-----------------	--------------------------

15 x 15	5,5 x 11	10 - 12	22	041416
---------	----------	---------	----	--------



A x B	A x B	Ø cm	cm ²	Blanco Blanc White
-------	-------	------	-----------------	--------------------------

15 x 15	5,5 x 11	10 - 12	0 - 50	041430
---------	----------	---------	--------	--------



Rejillas de ABS
Grilles en ABS
ABS Grilles



EAN = 8421272 + Ref.

EMPOTRABLES A TUBO | ENCASTRER A TUBE | FOR BUILT-IN TUBE MOUNTING



Multidiámetro. Lamas Móviles.
Multi diamètre. Volets mobiles.
Multidiameter. Movable planks.

A x B cm	Ø cm	cm ²	Blanco Blanc White Bianco	Arena Sable Sand Sabbia
16 x 15,5	10 - 13	0 - 71	041447	041454



4 patillas metálicas | 4 broches métalliques
4 metal pins

Acero
Acier
Steel

040013



Estándar | Standard | Standard

Ø cm	Ø cm	cm ²	Blanco Blanc White	Arena Sable Sand
13,5	8 - 12,5	33	040976	041157
17,5	12,5 - 16	52	040983	041164
23,5	16,5 - 22	97	041140	041133



Con clips | Avec clips | With lock clips

Ø cm	Ø cm	cm ²	Blanco Blanc White	Arena Sable Sand	Antracita Anthracite Anthracite	Blanco Blanc White
10	8 - 9	19	040990	041041	041713	
12,1	10 - 11	30	041003	041058	041720	027069
14,7	12,5 - 14	47	041010	041072	041737	027076
18,2	16 - 17	81	041027	041089		



Rejillas de ABS
Grilles en ABS
ABS Grilles





EAN = 8421272 + Ref.

EMPOTRABLES A TUBO | ENCASTRER A TUBE FOR BUILT-IN TUBE MOUNTING





Redondas (GAT) | Rondes (GAT) Circulars (GAT)

 Ø cm	 Ø cm	 cm ²	Blanco Blanc White
10,5	8 - 9	25	032001
12,5	10	42	032018
13,2	11	53	032025
14,4	12 - 12,5	64	032032
16	14	87	032049
18	16	115	032056







Cuadradas (GETM) | Carrées (GETM) Square (GETM)

 A x B cm	 Ø cm	 cm ²	Blanco Blanc White
11 x 11	8 - 9	9,2	032063
12,5 x 12,5	10	19	032070
14 x 14	11 - 12	23	032087
15 x 15	12,5	29	032094
16,5 x 16,5	14	70	032100
18,4 x 18,4	16	85	032117



Cuadradas (GETM+) | Carrées (GETM+) Square (GETM+)

 A x B cm	 Ø cm	 cm ²	Blanco Blanc White	Antracita Antracite Anthracite	 SPECIAL Blanco Blanc White
12,5 x 12,5	10	16	046558	041782	
13,8 x 13,8	11	21	046565	041799	
14,8 x 14,8	12	30	046572	041805	027113



Rejillas de ABS
Grilles en ABS
ABS Grilles





EAN = 8421272 + Ref.

EMPOTRABLES A TUBO | ENCASTRER A TUBE
FOR BUILT-IN TUBE MOUNTING



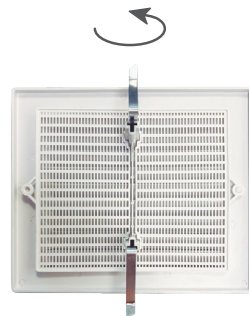
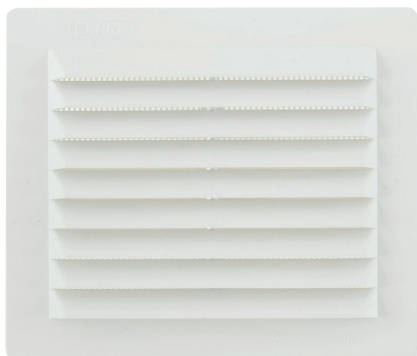

Anti-lluvia | Anti-pluie | Rain-proof

 A x B	 A x B	 cm ²	Blanco Blanc White
13,5 x 13,5	11 x 11	42	040853
18,2 x 18,2	15,9 x 15,9	105	040877
23 x 23	20,6 x 20,6	203	040884
13,5 x 30,4	11 x 27,2	136	040747
23 x 13,5	20,7 x 11	100	040679



Anti-lluvia | Anti-pluie | Rain-proof

 A x B	 A x B	 cm ²	Blanco Blanc White
15,5 x 18,3	9 - 16	69	040655



Rejillas de ABS
Grilles en ABS
ABS Grilles



EAN = 8421272 + Ref.

AEROVENTILADORES DE FUNCIÓN MECÁNICA | AÉRATEURS A LAMELLES MECHANICAL AIR VENTILATORS





Regulable. Poliestireno transparente
Réglable. Polystyrène transparent
Adjustable. Transparent polystyrene

 Ø cm	 Ø cm	 cm ²	Trans
16,7	15,7	0 - 107	041294



Especial GAS. Poliestireno transparente
Spécial GAZ. Polystyrène transparent
Special Gas. Transparent polystyrene

 Ø cm	 Ø cm	 cm ²	Blanco Blanc White
16,7	15,7	163	041324
21	19,3	229	041331



2 POSIBILIDADES DE INSTALACIÓN | 2 POSSIBILITÉS D'INSTALLATION 2 INSTALLATION POSSIBILITIES

empotrar con pre-marco | encastré avec précadre
recessed with pre-frame

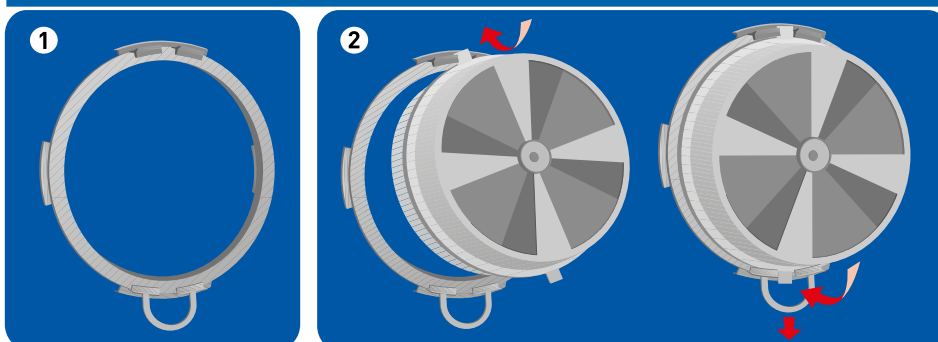

empotrar | à encastrer
embedded

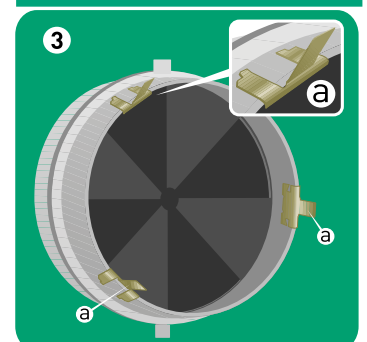

Extractores y accesorios de Aireación
 Extracteurs et accessoires Aération
 Extractors and Ventilation accessories

EAN = 8421272 + Ref.

OPTIMA



- Extractor axial para ventilación continua o periódica de baños, cocinas y otros espacios públicos.
- Bajo nivel sonoro.
- Capacidad de extracción máxima de 183 m³/h.
- Extracteur axial pour la ventilation régulière ou continue de salles de bains, cuisines et autres espaces publics.
- Faible niveau de bruit.
- Capacité d'extraction maximale de 183 m³/h.
- Axial extractor for continuous or periodic ventilation of bathrooms, kitchens and other public areas.
- Low noise level.
- Maximum extraction capacity 183 m³/h.

Dimensiones | Dimensions | Sizing

	mm	d	A	B	X	Y	E	F*	C
OPTIMA 4	100	150	150	135	135	55	8	22	
OPTIMA 5	125	175	175	160	160	61	10	23	

Características | Caractéristiques
 Features

	OPTIMA 4	OPTIMA 5
Ø mm	100	125
(m3/h)	97	183
W	14	14
dB (A)	35	36
Kg	0,44	0,5

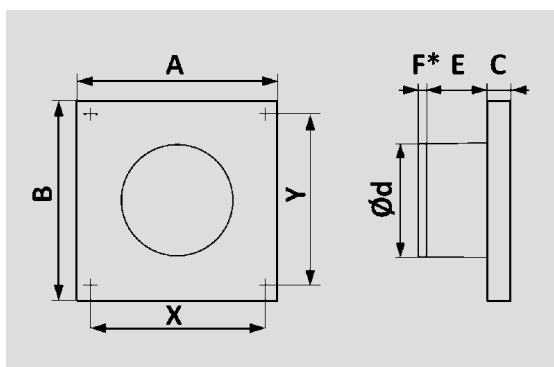

COLOCACIÓN | PLACEMENT | SETTING

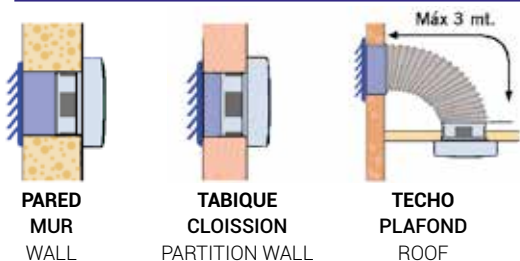

Versiones | Versions | Versions

Ø mm				
100	082037	082051	082099	082075
125	082044	082068	082105	082082



IP 24

Extractores y accesorios de Aireación
 Extracteurs et accessoires Aération
 Extractors and Ventilation accessories

EAN = 8421272 + Ref.

SLIM



- Extractor axial para ventilación continua o periódica de baños, cocinas y otros espacios públicos.
- Motor de rodamiento de bolas. Vida útil prolongada (hasta 40.000 horas de funcionamiento) y un bajo consumo de energía.
- Bajo nivel sonoro.
- Capacidad de extracción máxima de 250 m³/h.
- Extracteur axial pour la ventilation régulière ou continue de salles de bains, cuisines et autres espaces publics.
- Moteur à roulement à billes. Longue durée de vie (jusqu'à 40 000 heures de fonctionnement) et faible consommation d'énergie.
- Faible niveau de bruit.
- Capacité d'extraction maximale de 250 m³/h.
- Axial extractor for continuous or periodic ventilation of bathrooms, kitchens and other public areas.
- Ball bearing motor. Long service life (up to 40,000 hours of operation) and low power consumption.
- Low noise level.
- Maximum extraction capacity 250 m³/h.

Dimensiones | Dimensions | Sizing

mm	d	A	B	X	Y	E	F+	C
SLIM 4	100	160	160	140	140	76	7	9
SLIM 5	125	180	180	160	160	82	8,5	9
SLIM 6	150	205	205	187	187	86	10	9

Características | Caractéristiques | Features

	SLIM 4	SLIM 5	SLIM 6
Ø mm	100	125	150
(m3/h)	90	140	250
W	7,8	10	10
dB (A)	25	30	33
Kg	0,5	0,6	0,72

Versiones | Versions | Versions

Ø mm				
100	081887	081894	081931	081948
125	081900	081917	081955	
150	081924			

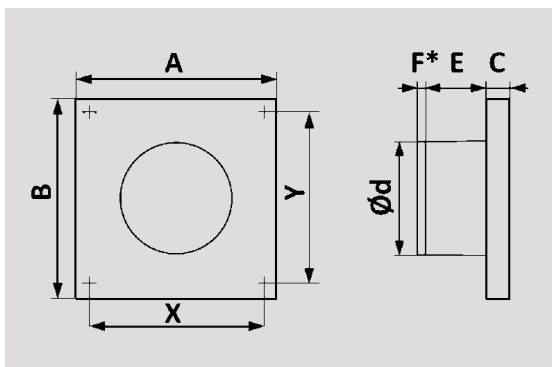

COLOCACIÓN PLACEMENT SETTING

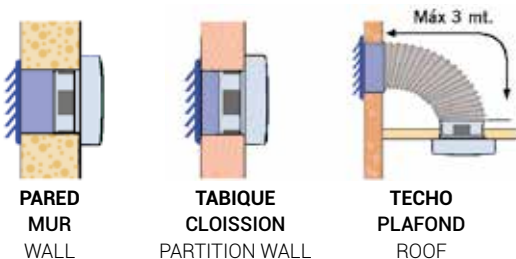

IP 24
 IP 25



Extractores y accesorios de Aireación
 Extracteurs et accessoires Aération
 Extractors and Ventilation accessories

EAN = 8421272 + Ref.

QUADRO

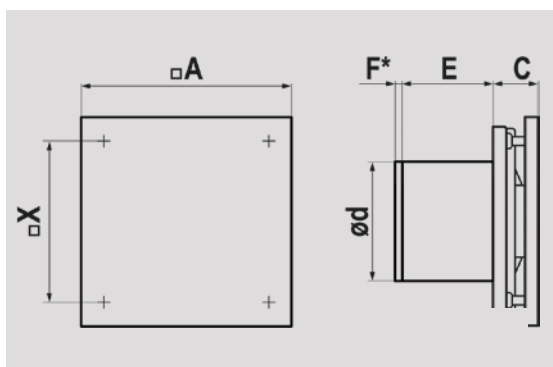

COLOCACIÓN PLACEMENT SETTING

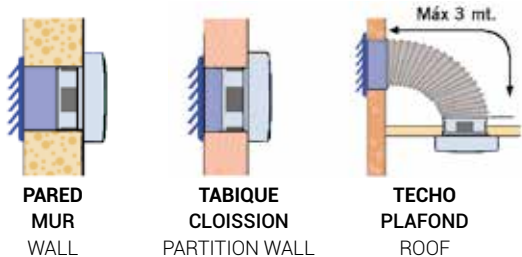

IP 24

El clásico extractor de panel frontal cerrado, que simplifica el mantenimiento del ventilador. Quadro viene equipado en un panel blanco como estándar, incorpora siete paneles de reemplazo de color disponibles por separado. Se incluye una plantilla de instalación para un montaje sin complicaciones.

Le classique extracteur à panneau frontal fermé, qui simplifie l'entretien du ventilateur. Quadro est équipé d'un panneau blanc de série, avec sept panneaux de remplacement disponibles séparément. Un modèle d'installation est inclus pour un montage sans tracas.

The classic closed front panel extractor, which simplifies fan maintenance. Quadro comes equipped in a white panel as standard, incorporates seven replacement color panels available separately. An installation template is included for hassle-free assembly.

Dimensiones | Dimensions | Sizing

mm	d	A	X	E	F*	C
QUADRO	98	172	135	74	6	38
QUADRO	123	200	160	79	6	38

Características | Caractéristiques
 Features

	OPTIMA 4	OPTIMA 5
Ø mm	98	123
(m3/h)	90	140
W	16	20
dB (A)	35	36
Kg	00	00

Versiónes | Versions | Versions

Ø mm			
100	080903	080941	080910
125	080927	080958	080934



Accesorios | Accessoires | Accessories

	Negro Noir Black	Gris Grey
	081092	081108



VMC

VMC MONO

NEW

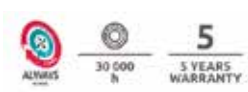

- De 2 velocidades
- Funcionamiento continuo
- Temperatura máxima de funcionamiento 40°C
- Instalación del techo permitida
- 5 años de garantía

- 2 vitesses
- Fonctionnement continu
- Température maximale de fonctionnement 40°C
- Installation du toit autorisée
- 5 ans de garantie

- 2-speed
- Continuous operation
- Maximum operating temperature 40°C
- Roof installation allowed
- 5 years warranty

Dimensiones | Dimensions | Sizing

mm	d	A	B	X	Y	W	Z
100	100	109	109	160	160	102	77
125	125	137	137	200	200	102	77

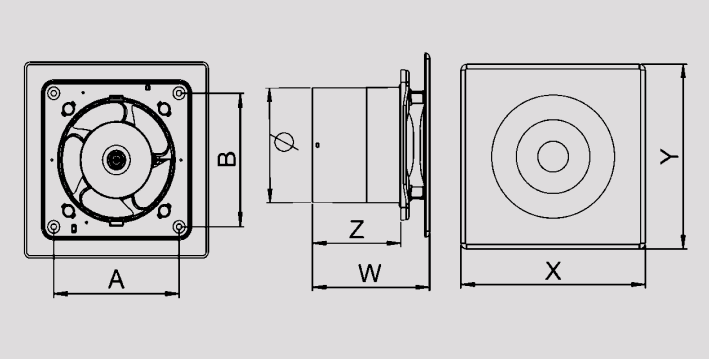

Características | Caractéristiques
Features

	100	125
Ø mm	100	125
(m3/h)	42	55
W	4	6
dB (A)	26	24

COLOCACIÓN | PLACEMENT | SETTING

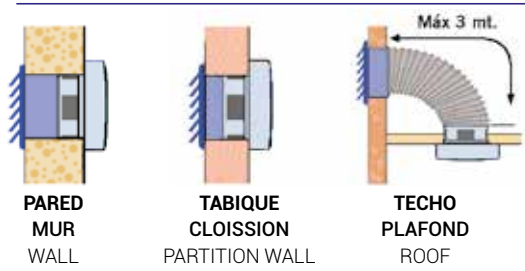

Versiones | Versions | Versions

Ø mm		
100	290237	290244
125	290251	290268



IP 24 CE

Extractores y accesorios de Aireación
 Extracteurs et accessoires Aération
 Extractors and Ventilation accessories

EAN = 8421272 + Ref.

CONDUCT



- Extractor tubular en línea para conductos rígidos o flexibles.
- Capacidad de extracción máxima de 280 m³/h.
- Motor de bajo voltaje
- Diseñado para funcionamiento continuo.
- Extracteur tubulaire en ligne pour tubes et gaines rigides ou flexibles.
- Capacité d'extraction maximale de 280 m³/h.
- Moteur basse tension.
- Conception pour un fonctionnement continu.
- In-line tubular extractor for rigid or flexible ducts.
- Maximum extraction capacity 280 m³/h
- Low voltage engine.
- Designed for continuous operating.



Dimensiones | Dimensions | Sizing

mm	d	D	A	E	F*
VP 4	100	103	80	30	8
VP 5	125	128	82	30	10
VP 150	150	153	104	35	10

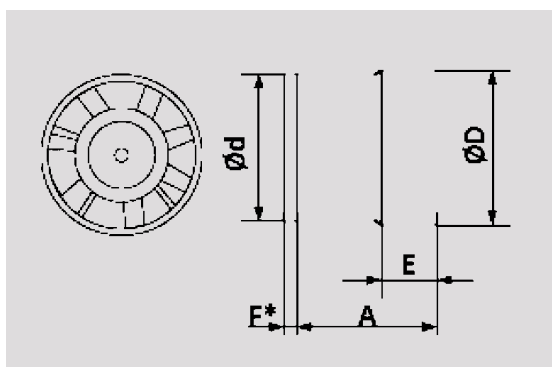

COLOCACIÓN PLACEMENT SETTING

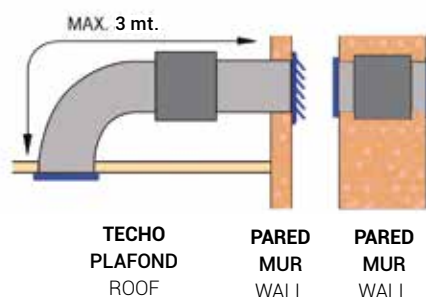

Características | Caractéristiques Features

	VP 4	VP 5	VP 6
Ø mm	100	125	150
(m ³ /h)	107	190	280
W	14	18	22
dB (A)	35	36	37
Kg	0,31	0,41	0,6

Versiones | Versions | Versions

Ø mm	S
100	082006
125	082013
150	082020

IP 24



Extractores y accesorios de Aireación
 Extracteurs et accessoires Aération
 Extractors and Ventilation accessories

EAN = 8421272 + Ref.

CONDUCT PLUS



- Extractor tubular en línea para conductos rígidos o flexibles para ventilación continua o periódica de baños, cocinas y otros espacios públicos.
- Capacidad de extracción máxima de 320 m³/h.
- Motor de bajo voltaje
- Diseñado para funcionamiento continuo.
- Extracteur tubulaire en ligne pour tubes et gaines rigides ou flexibles pour la ventilation régulière ou continue de salles de bains, cuisines et autres espaces publics.
- Capacité d'extraction maximale de 320 m³/h.
- Moteur basse tension.
- Conception pour un fonctionnement continu.
- In-line tubular extractor for rigid or flexible ducts for continuous or periodic ventilation of bathrooms, kitchens and other public areas with sound limitations
- Maximum extraction capacity 320 m³/h
- Low voltage engine.
- Designed for continuous operating.

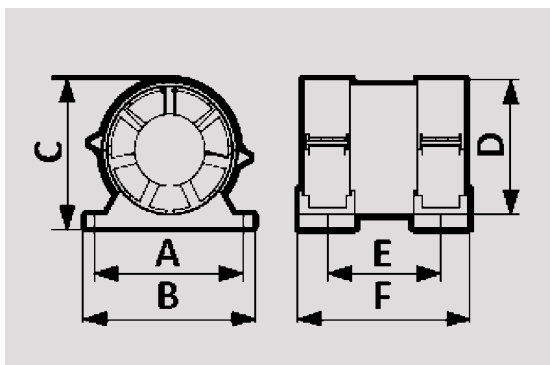

Dimensiones | Dimensions | Sizing

mm	A	B	C	D	E	F
PRO 4	122	138	119	103,6	94	139
PRO 5	147	163	144	128,6	101	146
VP 150	182	198	179	163,5	104	154

Características | Caractéristiques | Features

	PRO 4	PRO 5	PRO 6
Ø mm	100	125	160
(m3/h)	115	195	320
W	14	18	22
dB (A)	32	34	36
Kg	0,51	0,55	0,87

Versiones | Versions | Versions

Ø mm	S
100	081979
125	081986
150	081993

COLOCACIÓN | PLACEMENT | SETTING

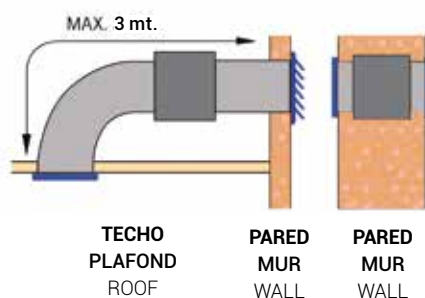

IP 24



Accesorios para extractores
 Accessoires extraction
 Accessories for extractors

EAN = 8421272 + Ref.

VÁLVULA ANTIRETORNO | CLAPET ANTI-RETOUR | CHECK VALVE



La válvula anti-retorno está diseñada para extractores axiales domésticos y es un dispositivo de protección contra la corriente de aire desde el conducto de ventilación hasta el interior de la vivienda. Proporciona protección contra todo tipo de olores que pueden filtrarse por los agujeros de ventilación. Solapas resistentes al desgaste. Facilidad de instalación.

Le clapet anti-retour est conçu pour les ventilateurs axiaux domestiques et est un dispositif de protection contre les courants d'air du conduit de ventilation vers l'appartement. Fournit une protection contre toutes sortes d'odeurs qui peuvent s'infiltrer à travers les orifices de ventilation. Portez des volets résistants. Facilité d'installation.

The check valve is designed for domestic axial fans and it is a protection device against the draft of air from the ventilation duct to the apartment. Provides protection against all kinds of odors that can seep through the ventilation holes. Wear resistant flaps. Ease of installation.

Ø cm	
Ø - 100	082112
Ø - 125	082129
Ø - 150	082136



REGULADOR | RÉGULATEUR | CONTROLLER



Los reguladores se utilizan en sistemas de ventilación para encender / apagar y controlar la velocidad de rotación de los motores eléctricos monofásicos de los extractores. Es posible establecer la velocidad mínima del ventilador mediante una resistencia variable a la placa del controlador. El encendido, apagado y regulación de la velocidad de rotación del ventilador se realizan mediante el mando. Es posible controlar varios ventiladores si la corriente consumida total no supera el valor máximo de corriente permitido del regulador. Potencia max 2,5 A.

Les régulateurs sont utilisés dans les systèmes de ventilation pour allumer / éteindre et contrôler la vitesse de rotation des moteurs électriques monophasés dans les ventilateurs. Il est possible de régler la vitesse minimale du ventilateur à l'aide d'une résistance variable sur la carte contrôleur. L'activation, la désactivation et la régulation de la vitesse de rotation du ventilateur se réalisent au moyen de la commande. Il est possible de contrôler plusieurs ventilateurs si le courant total consommé ne dépasse pas la valeur de courant maximum autorisée du régulateur. Puissance max. 2,5 A

Regulators are used in ventilation systems to switch on / off and control the rotation speed of single-phase electric motors in fans. It is possible to set the minimum fan speed using a variable resistor on the controller board. The on, off and regulation of the speed of rotation of the fan realize by means of the control. It is possible to control several fans if the total current consumed does not exceed the maximum allowed current value of the regulator. Power max. 2,5 A.

Dim. cm	
8 x 8 x 6,8	082143



Accesorios para conectividad de tubos
 Accessoires de connectivité
 Accessories for duct connection

EAN = 8421272 + Ref.



Tubo de PVC | Gaine de PVC | PVC duct.

Ø cm	Ø cm	2,5 m	5 m
Ø - 80	Ø - 83	081283	081290
Ø - 100	Ø - 103	081306	081313
Ø - 110	Ø - 113	081320	081337
Ø - 125	Ø - 128	081344	081351
Ø - 150	Ø - 153	081368	081375
Ø - 160	Ø - 163	080385	080392

Velocidad del aire - Vitesse de l'air - Air speed : MAX 20 m/''
 Temperatura - Température - Temperature : MIN/MAX -20/+70°C
 Presión - Pression - Pressure : Max. 1500 Pa
 Difícil ignición - Difficile à enflammer - Difficult to ignite



Tubo flexible en alu. | Gaine souple d'alu | Flexible alu. duct

Ø cm	Ø cm	2,5 m	10 m
Ø - 80	Ø - 84	081382	081399
Ø - 100	Ø - 104	081405	081412
Ø - 110	Ø - 114	081429	081436
Ø - 125	Ø - 129	081443	081450
Ø - 150	Ø - 154	081467	081474

Velocidad del aire - Vitesse de l'air - Air speed : MAX 30 m/''
 Temperatura - Température - Temperature : MIN/MAX -30/+150°C
 Presión - Pression - Pressure : Max. 3000 Pa
 Difícil ignición - Difficile à enflammer - Difficult to ignite



Tubo flexible semi-rígido en aluminio | Gaine de d'aluminium semi-rigide
 Flexible semi-rigid aluminium duct

Ø cm	Ø cm	1,5 m	3 m
Ø - 80	Ø - 85	081481	081498
Ø - 100	Ø - 105	081504	081511
Ø - 110	Ø - 115	081528	081535
Ø - 125	Ø - 130	081542	081559
Ø - 150	Ø - 155	081566	081573
Ø - 160	Ø - 165	082600	082617

Velocidad del aire - Vitesse de l'air - Air speed : MAX 30 m/''
 Temperatura - Température - Temperature : MIN/MAX -30/+250°C
 Presión - Pression - Pressure : Max. 3000 Pa
 Difícil ignición - Difficile à enflammer - Difficult to ignite



Tubo flexible | Tube souple | Flexible duct

Dim. mm	Blanco Blanc White	
Ø - 102 L = 3000	047883	



Tubo flexible aislado alu | Tube flexible isolé alu
 Insulated flexible tube alu

Ø cm	3 m	6 m
Ø - 80	082419	082440
Ø - 125	082426	082457
NEW Ø - 160	082433	082464

Velocidad del aire - Vitesse de l'air - Air speed : MAX 30 m/''
 Temperatura - Température - Temperature : MIN/MAX -30/+250°C
 Presión - Pression - Pressure : Max. 3000 Pa
 Difícil ignición - Difficile à enflammer - Difficult to ignite

Accesorios para conectividad de tubos
 Accessoires de connectivité
 Accessories for duct connection

EAN = 8421272 + Ref.



Válvula antiretorno de metal | Vanne anti-retour en métal
 Non-return valve made of metal

Dim. mm	ALU
Ø-100	082549
Ø-125	082556
Ø-150	082563
Ø-160	082532



Empalme tubo | Manchon | Duct splicing

Dim. mm	ALU
Ø-80	081757
Ø-100	081764
Ø-110	081771
Ø-125	081788
Ø-150	081795



Bolsa de bridas de acero | Sac à bride d'acier
 Bag of flanges steel

Dim. mm	ALU
60 a 215 mm (2 un)	082396
60 a 215 mm (10 un)	082402



Cinta adhesiva Alu. | Bande autocollante Alu.
 Alu. adhesive tape

Dim. mm	ALU
50 mm x 10 m	081870
50 mm x 50 m	082518



Tubos y accesorios para conectividad. PVC

Tubes et accessoires de connectivité. PVC

Pipes and accessories for connectivity. PVC

EAN = 8421272 + Ref.

De material ignífugo autoextinguible. Temperatura de trabajo 80°C. Ensamblaje modular.
 Matériau ignifugeant et auto-extinguible. Température de travail 80 °C. Assemblage modulaire.
 Of fireproof and self-extinguishing material. Working temperature 80°C. Modular assembly.



Ø 100 y 55 x 110

Ø 120 y 75 x 150

Tubo rígido | Tube rigide | Rigid duct

Dim. mm	Blanco Blanc White
55 x 110 L = 1.000	080019
55 x 110 L = 1.500	080002

Dim. mm	Blanco Blanc White
75 x 150 L = 1.000	080439
75 x 150 L = 1.500	080415



Tubo plegable | Tube pliant | Folding duct

Dim. mm	Blanco Blanc White
55 x 110 L = 1.000	080033
55 x 110 L = 1.500	080040

Dim. mm	Blanco Blanc White
75 x 150 L = 1.000	080446
75 x 150 L = 1.500	080453



Tubo rígido | Tube rigide | Rigid duct

Dim. mm	Blanco Blanc White
Ø - 100 L = 1.000	080057
Ø - 100 L = 1.500	080071

Dim. mm	Blanco Blanc White
Ø - 120 L = 1.000	080460
Ø - 120 L = 1.500	080484



Tubos y accesorios para conectividad. Poliestireno

Tubes et accessoires de connectivité. Polystyrène

Pipes and accessories for connectivity. Polystyrene



Empalme | Manchon | Splice

Dim. mm	Blanco Blanc White
55 x 110	080088

Dim. mm	Blanco Blanc White
75 x 150	080491



Empalme | Manchon | Splice

Ø Dim. mm	Blanco Blanc White
Ø - 100	080095

Ø Dim. mm	Blanco Blanc White
Ø - 120	080507



Tubos y accesorios para conectividad. Poliestireno
Tubes et accessoires de connectivité. Polystyrène
Pipes and accessories for connectivity. Polystyrene

EAN = 8421272 + Ref.

De material ignífugo autoextinguible. Temperatura de trabajo 80°C. Ensamblaje modular.
 Matériau ignifugeant et auto-extinguible. Température de travail 80 °C. Assemblage modulaire.
 Of fireproof and self-extinguishing material. Working temperature 80°C. Modular assembly.



Ø 100 y 55 x 110

Empalme mixto recto | Manchon droit mixte
 Straight mixed splice

Dim. mm	Blanco Blanc White	Dim. mm	Blanco Blanc White
Ø - 100 a 55 x 110	080101	Ø - 120 a 75 x 150	080514



Codo mixto 90° | Coude mixte 90
 90° elbow joint

Dim. mm	Blanco Blanc White	Dim. mm	Blanco Blanc White
Ø - 100 a 55 x 110	080118	Ø - 120 a 75 x 150	080521



Codo 90° | Coude 90° | 90° elbow

Dim. mm	Blanco Blanc White	Dim. mm	Blanco Blanc White
55 x 110	080125	75 x 150	080538



Codo redondo flexible | Coude souple ronde
 Flexible circular elbow joint

Dim. mm	Blanco Blanc White	Dim. mm	Blanco Blanc White
Ø - 100 L = 500	080149	Ø - 120 L = 500	080552



Codo rect. flexible | Coude souple rect.
 Flexible rect. elbow joint

Dim. mm	Blanco Blanc White	Dim. mm	Blanco Blanc White
55 x 110 L = 500	080156	75 x 150 L = 150	080668



Tubos y accesorios para conectividad. Poliestireno
 Tubes et accessoires de connectivité. Polystyrène
 Pipes and accessories for connectivity. Polystyrene

EAN = 8421272 + Ref.

De material ignífugo autoextinguible. Temperatura de trabajo 80°C. Ensamblaje modular.
 Matériau ignifugeant et auto-extinguible. Température de travail 80 °C. Assemblage modulaire.
 Of fireproof and self-extinguishing material. Working temperature 80°C. Modular assembly.



Ø 100 y 55 x 110

Ø 120 y 75 x 150

Codo 90° | Coude 90° | 90° elbow

Dim. mm	Blanco Blanc White	Dim. mm	Blanco Blanc White
55 x 110	080163	75 x 150	080576



Codo 90° | Coude 90° | 90° elbow

Ø Dim. mm	Blanco Blanc White	Ø Dim. mm	Blanco Blanc White
Ø - 100	080170	Ø - 120	080583



Codo 45° | Coude 45° | 45° elbow

Dim. mm	Blanco Blanc White
55 x 110	080132



Codo 45° | Coude 45° | 45° elbow

Ø Dim. mm	Blanco Blanc White
Ø - 100	080187



Remate pared | Platine finition | Wall finish

Ø Dim. mm	Blanco Blanc White	Ø Dim. mm	Blanco Blanc White
Ø - 100	080194	Ø - 120	080613

Tubos y accesorios para conectividad. Poliestireno
Tubes et accessoires de connectivité. Polystyrène
Pipes and accessories for connectivity. Polystyrene



EAN = 8421272 + Ref.

De material ignífugo autoextinguible. Temperatura de trabajo 80°C. Ensamblaje modular.
 Matériau ignifugeant et auto-extinguible. Température de travail 80 °C. Assemblage modulaire.
 Of fireproof and self-extinguishing material. Working temperature 80°C. Modular assembly.



Ø 100 y 55 x 110

Ø 120 y 75 x 150

Remate pared | Platine finition | Wall finish

Ø Dim. mm	Blanco Blanc White	Ø Dim. mm	Blanco Blanc White
55 x 110	080200	75 x 150	080606



Abrazadera | Fixation | Clamp

Dim. mm	Blanco Blanc White	Dim. mm	Blanco Blanc White
55 x 110	080286	75 x 150	080644



Abrazadera | Fixation | Clamp

Ø Dim. mm	Blanco Blanc White	Ø Dim. mm	Blanco Blanc White
Ø - 100	080293	Ø - 120	080651



Aro reductor | Reducteur | Ring adapter

Ø Dim. mm	Blanco Blanc White
Ø - 125 a Ø - 120	080682



Aro reductor | Reducteur | Ring adapter

Ø Dim. mm	Blanco Blanc White
Ø - 80 a Ø - 150	082327
Ø - 125 a Ø - 100	080309



Expositores/Implantaciones
 Expositeurs/Implantations
 Displays and In-store concessions

EAN = 8421272 + Ref.

JUNIOR ALUMINIO Y ABS | JUNIOR ALUMINIUM Y ABS JUNIOR ALUMINIUM Y ABS



Ref. JUNIOR ALUMINIO - 009041

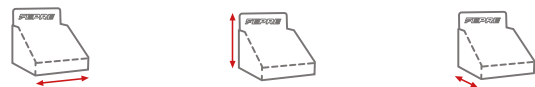

	41 cm	40 cm	40 cm
	REJILLA I GRILLES I GRILLES		
		UDS.	REF
	Rejilla Empotrar a tubo D-12 cm Blanco VRAC	5	027038
	Rejilla Empotrar a tubo D-10 cm Blanco VRAC	5	027021
	Rejilla Regulable Blanca Poliest. 17x19	5	004725
	Rejilla s/b 0,6 Lacado Blanco 20x20	10	053501
	Rej. s/b 0,8 c/Mosq. Lacado Blanco 20x20. CON GANCHO	5	002752
	Rej. Strong c/Mosq. 15x15 Nat (G)	5	003322
	Rejilla s/b 0,6 Alum.Nat 15x15	10	053334
	Rejilla s/b 0,6 Lacado Blanco 15x15	10	053464
	Rej. s/b 0,8 c/Mosq. Lacado Blanco 15x15. CON GANCHO	5	002783
	Rejilla s/b 0,6 Lacado Blanco 10x10	10	053433
	Rejilla s/b 0,6 Lacado Blanco 10x20	10	053440
	Rej. s/b 0,8 c/Mosq. Lacado Blanco 10x10 CON GANCHO	5	002714
	Rej. s/b 0,8 c/Mosq. Lacado Blanco 10x20 CON GANCHO	5	002721

Ref. JUNIOR ABS - 009058

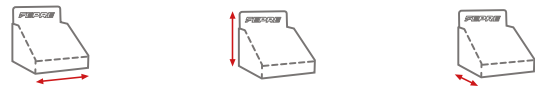

	48 cm	40 cm	40 cm
	REJILLA I GRILLES I GRILLES I GRIGLIE		
		UDS.	REF
	Rej. Empotrar SHUN c/pestaña 13,3x26+Marco ABS Blanco VRAC	5	027007
	Rej. Empotrar Regulable SHUN 13,3x26+Marco ABS Blanco VRAC	5	027014
	Rejilla Empotrar D-10-12 cm Lam Mov ABS Blanco VRAC	4	027090
	Rejilla Empotrar D-11,8 cm ABS Blanco + Mosq. VRAC	5	027052
	Rejilla Empotrar D-9,4 cm ABS Blanco + Mosq. VRAC	5	027045
	Rej. Atornillar 14,6x17,5 cm ABS Blanco + Mosq. VRAC	5	027083
	Rej. Emp+Clipsar D-12,5-14 cm ABS Blanco +Mosq VRAC	5	027076
	Rej. Emp+Clipsar D-10-11 cm ABS Blanco +Mosq VRAC	5	027069
	Rej. Emp+Clipsar D-12 cm ABS Blanco VRAC	3	027113

Expositores/Implantaciones
Expositeurs/Implantations
 Displays and In-store concessions

EAN = 8421272 + Ref.

VENT | VENT | VENT | VENT

Ref. VENT - 009034

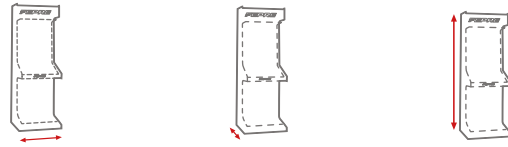

70 cm	60 cm	230 cm	UDS.	REF
REJILLA I GRILLES I GRILLES I GRIGLIE				
Rej. s/b 0,8 c/Mosq. Lacado Blanco 17x17. CON GANCHO			10	002813
Rej. s/b 0,8 c/Mosq. Lacado Blanco 25x25. CON GANCHO			10	002509
Rejilla Empotrable Blanca Polies. 0,8 16x16			5	004206
Rej. s/b 0,8 c/Mosq. Lacado Blanco 15x15. CON GANCHO			10	002783
Rej. s/b 0,8 c/Mosq. Lacado Blanco 5x25. CON GANCHO			10	040266
Rejilla Regulable Blanca Poliest. 17x19			5	004725
Rej. Strong 1,5mm. c/Mosq. 15x15 Blanco (G)			10	003322
Rej. s/b 0,8 c/Mosq. Lacado Blanco 20x20. CON GANCHO			10	002752
Rejilla Regulable Blanca Poliest. 4,5x24			5	040297
Rejilla Regulable Blanca Poliest. 17x13			5	004718
Rej. s/b 0,8 c/Mosq. Lacado Blanco 10x10. CON GANCHO			10	002714
Rej. s/b 0,8 c/Mosq. Lacado Blanco 10x10 CON GANCHO			10	002721
Rejilla Empotrar a tubo D-12 cm Regul. Alu Blanca			5	041690
Rej. Empotrar SHUN c/pestaña 13,3x26+Marco ABS Blanco VRAC			5	027007
Rej. Empotrar Regulable SHUN 13,3x26+Marco ABS Blanco VRAC			5	027014
Rejilla Empotrar D-10-12 cm Lam Mov ABS Blanco VRAC			4	027090
Rejilla Empotrar D-11,8 cm ABS Blanco + Mosq. VRAC			5	027052
Rejilla Empotrar D-9,4 cm ABS Blanco + Mosq. VRAC			5	027045
Rej. Atornillar 14,6x17,5 cm ABS Blanco + Mosq. VRAC			5	027083
Rej. Emp+Clipsar D-12,5-14 cm ABS Blanco +Mosq VRAC			5	027076
Rej. Emp+Clipsar D-10-11 cm ABS Blanco +Mosq VRAC			5	027069
Rej. Emp+Clipsar D-12 cm ABS Blanco VRAC			3	027113
Rejilla Empotrar a tubo D-12 cm Blanco VRAC			5	027038
Rejilla Empotrar a tubo D-10 cm Blanco VRAC			5	027021
Rej. Decorat. Empotr. DECOR 6,6x48 Blanca			10	028813
Rej. Decorat. Empotr. DECOR 6,6x28 Blanca			10	028806
Rej. -Difusor ACERO D- 125 Blanco			5	024235
Rejilla s/b 0,8 c/Mosq. Plata 10x10. CON GANCHO			10	002103
KIT 4 Rejillas Atornillar D-6,4 cm ABS Blanco			5	040921
Rej. -Difusor ACERO D- 100 Blanco			5	024228
Rejilla s/b 0,8 c/Mosq. Plata 15x15. CON GANCHO			10	002172
Rejilla s/b 0,8 c/Mosq. Plata 20x20. CON GANCHO			10	002141
Rej. Emp+Clipsar 11x11 cm ABS Blanco + Mosq			5	040853
KIT 4 Rejillas Empotrar D-4 cm ABS Blanco			5	040914
Rejilla Emp. c/ Patillas 10x10 cm ABS Blanco + Mosq			5	040815
Rejilla Atornillar 8,6x16,5 cm ABS Blanco + Mosq			5	040570
Rejilla s/b 0,6 Alum.Nat 10x10			10	053303
Rejilla s/b 0,6 Alum.Nat 20x20			10	053372
Rejilla s/b 0,6 Lacado Blanco 15x15			10	053464
Rejilla s/b 0,6 Alum.Nat 15x15			10	053334
Rejilla s/b 0,6 Lacado Blanco 10x10			10	053433
Rejilla s/b 0,6 Lacado Blanco 20x20			10	053501

Expositores/Implantaciones
 Expositeurs/Implantations
 Displays and In-store concessions



IMPLANTACIÓN REJILLAS
IMPLANTATION GRILLES
GRILLES IMPLANTATION

Ref. R-1. (METAL + PVC)

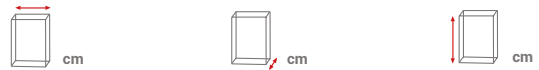

100

40

200

Góndola no incluida. Cartelería incluida | Gondole non incluse. Affiche incluse.
 Panel not included. Poster included.

Hacemos implantaciones a medida ¡CONTÁCTANOS!
 Nous réalisons implantations personnalisées CONTACTEZ-NOUS !
 We do customised implantations CONTACT US!



Expositores/Implantaciones
 Expositeurs/Implantations
 Displays and In-store concessions



IMPLANTACIÓN REJILLAS
IMPLANTATION GRILLES
GRILLES IMPLANTATION

Ref. R-2. (METAL + ABS)

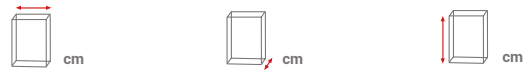

130 40 200

Góndola no incluida. Cartelería incluida | Gondole non incluse. Affiche incluse.
 Panel not included. Poster included.

Hacemos implantaciones a medida ¡CONTÁCTANOS!
 Nous réalisons implantations personnalisées CONTACTEZ-NOUS !
 We do customised implantations CONTACT US!



Expositores/Implantaciones
 Expositeurs/Implantations
 Displays and In-store concessions



IMPLANTACIÓN REJILLAS
IMPLANTATION GRILLES
GRILLES IMPLANTATION

Ref. R-3. (METAL + ABS)



200 40 200

Góndola no incluida. Cartelería incluida | Gondole non incluse. Affiche incluse.
 Panel not included. Poster included.

Hacemos implantaciones a medida ¡CONTACTANOS!
 Nous réalisons implantations personnalisées CONTACTEZ-NOUS !
 We do customised implantations CONTACT US!



Expositores/Implantaciones
 Expositeurs/Implantations
 Displays and In-store concessions



IMPLANTACIÓN TUBOS Y EXTRACTORES
IMPLANTATION TUBES ET EXTRACTEURS
PIPES AND EXTRACTORS IMPLANTATION

Ref. TBE-1.

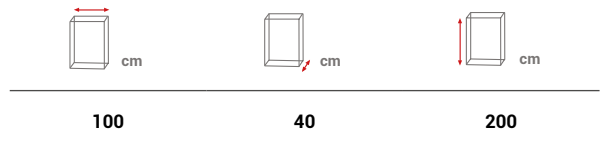

Góndola no incluida. Cartelería incluida | Gondole non incluse. Affiche incluse.
 Panel not included. Poster included.

Hacemos implantaciones a medida ¡CONTACTANOS!
 Nous réalisons implantations personnalisées CONTACTEZ-NOUS !
 We do customised implantations CONTACT US!



Expositores/Implantaciones
 Expositeurs/Implantations
 Displays and In-store concessions



IMPLANTACIÓN TUBOS Y EXTRACTORES
IMPLANTATION TUBES ET EXTRACTEURS
PIPES AND EXTRACTORS IMPLANTATION

Ref. TBE-2.



130 40 200

Góndola no incluida. Cartelería incluida | Gondole non incluse. Affiche incluse.
 Panel not included. Poster included.

Hacemos implantaciones a medida ¡CONTÁCTANOS!
 Nous réalisons implantations personnalisées CONTACTEZ-NOUS !
 We do customised implantations CONTACT US!



Expositores/Implantaciones
 Expositeurs/Implantations
 Displays and In-store concessions



IMPLANTACIÓN TUBOS Y EXTRACTORES
IMPLANTATION TUBES ET EXTRACTEURS
PIPES AND EXTRACTORS IMPLANTATION

Ref. TBE-3.

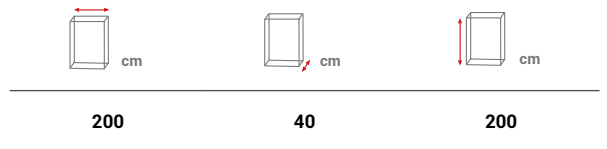

Góndola no incluida. Cartelería incluida | Gondole non incluse. Affiche incluse.
 Panel not included. Poster included.

Hacemos implantaciones a medida ¡CONTACTANOS!
 Nous réalisons implantations personnalisées CONTACTEZ-NOUS !
 We do customised implantations CONTACT US!



Expositores/Implantaciones
 Expositeurs/Implantations
 Displays and In-store concessions



IMPLANTACIÓN EXTRACCIÓN HUMOS
IMPLANTATION TUBES ET EXTRACTEURS
SMOKE EXTRACTION IMPLANTATION

Ref. AFS-100.



100



40



200

Góndola no incluida. Cartelería incluida | Gondole non incluse. Affiche incluse.
 Panel not included. Poster included.

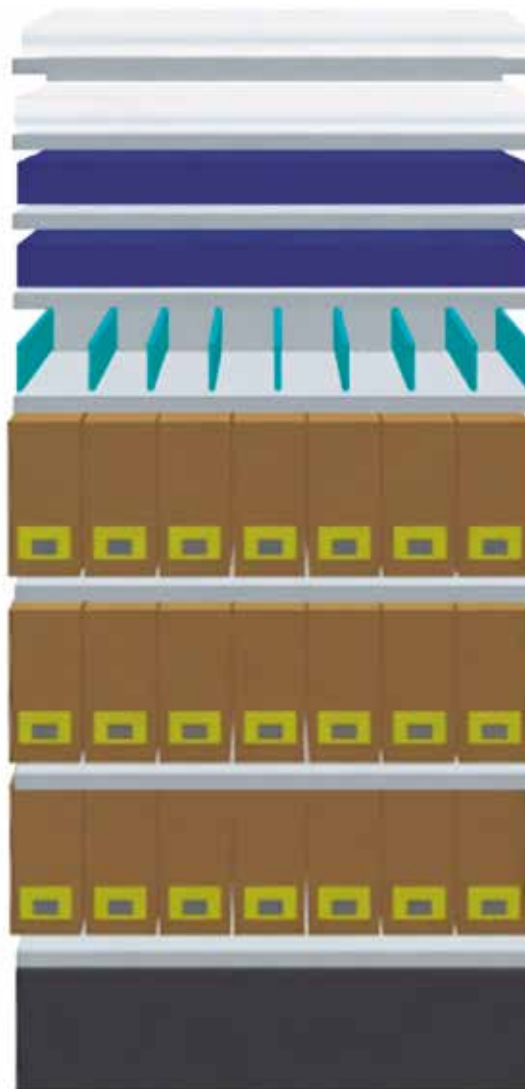

200 cm

100 cm

Expositores/Implantaciones
 Expositeurs/Implantations
 Displays and In-store concessions



IMPLANTACIÓN EXTRACCIÓN HUMOS
IMPLANTATION TUBES ET EXTRACTEURS
SMOKE EXTRACTION IMPLANTATION

Ref. AFS-130.

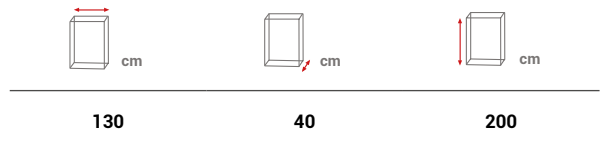

Góndola no incluida. Cartelería incluida | Gondole non incluse. Affiche incluse.
 Panel not included. Poster included.

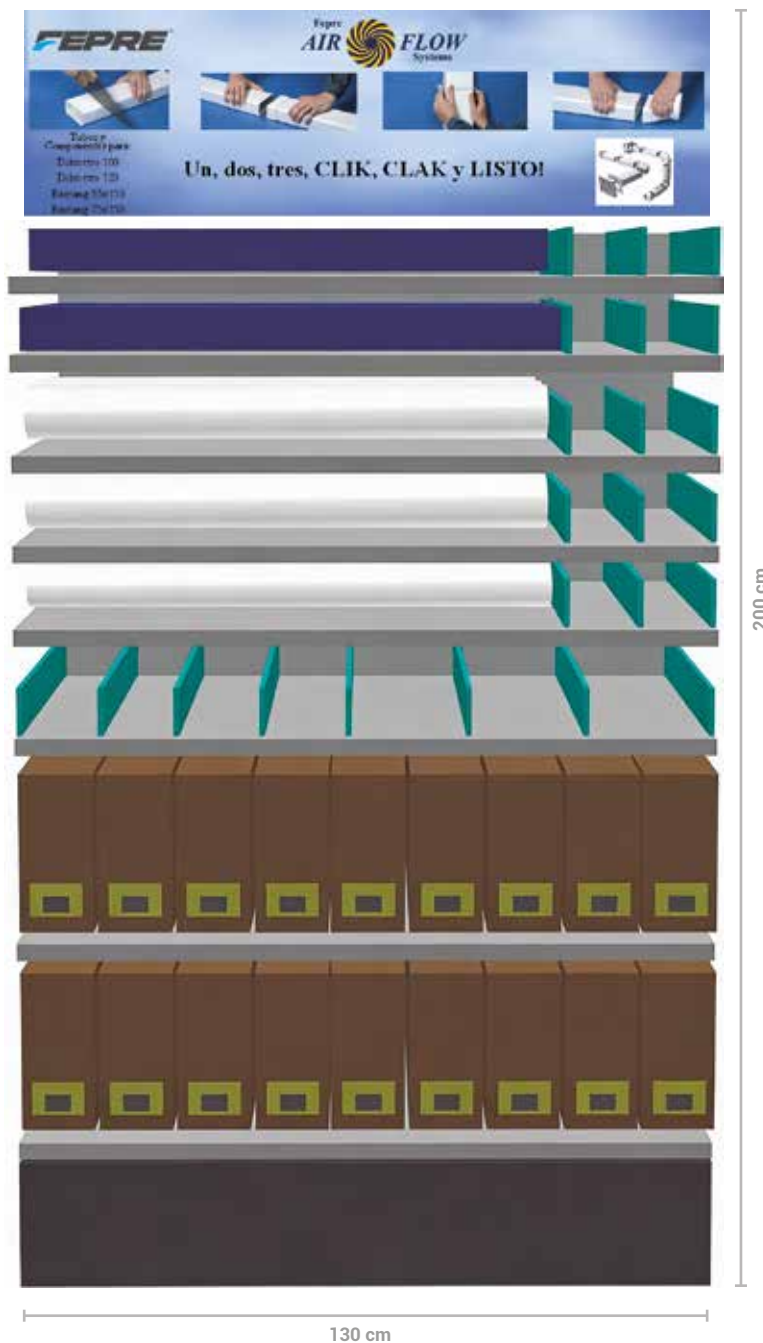

200 cm

130 cm

Expositores/Implantaciones
 Expositeurs/Implantations
 Displays and In-store concessions



IMPLANTACIÓN EXTRACCIÓN HUMOS
IMPLANTATION TUBES ET EXTRACTEURS
SMOKE EXTRACTION IMPLANTATION

Ref. AFS-200.

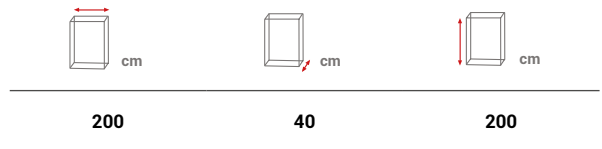

Góndola no incluida. Cartelería incluida | Gondole non incluse. Affiche incluse.
 Panel not included. Poster included.

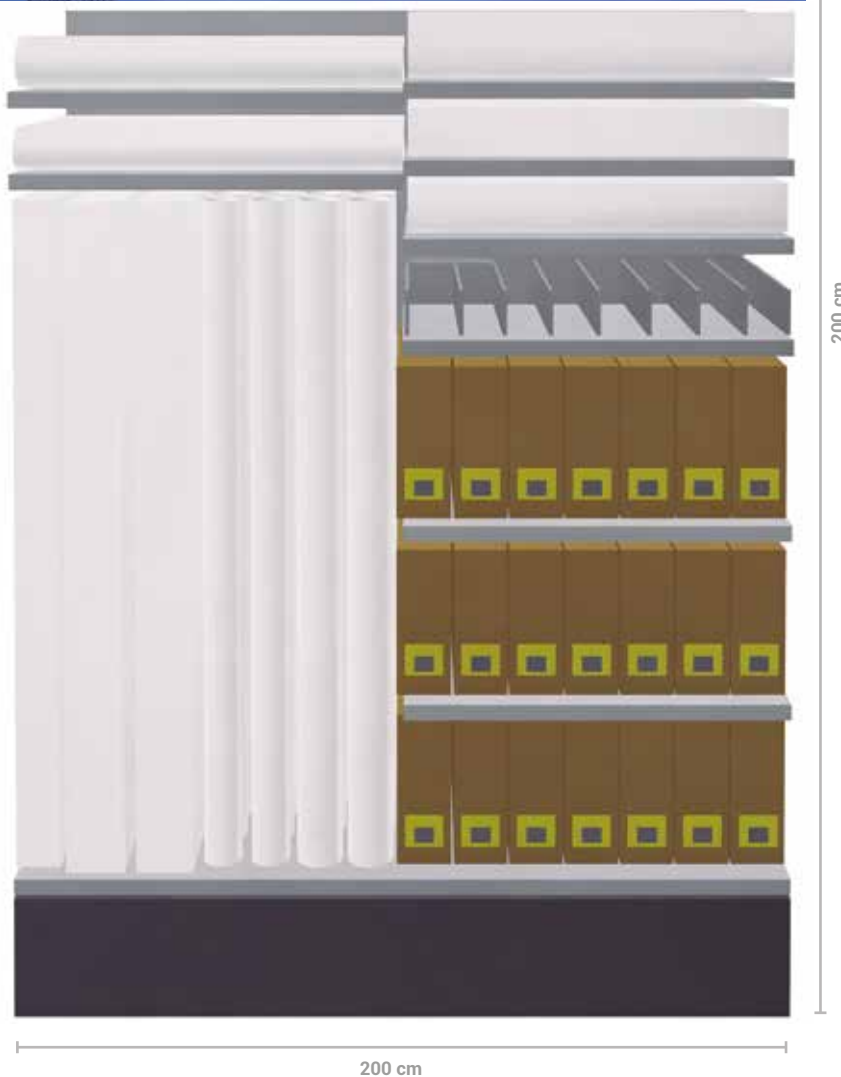

ORDENACIÓN AMÉNAGEMENT ORGANISATION

SOPORTES Y ESCUADRAS SUPPORTS ET ÉQUERRES WALL MOUNTS AND BRACKETS

- 62** **Escuadras de acero funcionales** | Équerres d'acier fonctionnelles | Wall mounts and brackets
- 68** **Escuadras acero ornamentales** | Équerres ornamentaux | Ornamental steel brackets
- 69** **Escuadras madera** | Équerres en bois | Wooden brackets
- 70** **Escuadras decorativas de acero** | Équerres decoratives d'acier | Decorative steel brackets

ESTANTES Y CLIPS | TABLETTES ET CLIPS | SHELVING MOUNTS AND BRACKETS

- 72** **Clips para estantes HomeDecor** | Clips pour tablettes HomeDecor | Clips for Homedecor shelving
- 73** **Estantes de madera HomeDecor** | Tablettes en bois HomeDecor | HomeDecor wooden shelving
- 74** **Estantes de fijación invisible HomeDecor** | Tablettes avec fixation invisible HomeDecor | HomeDecor invisible mounted invisible fastening

GUIAS Y CARTELAS | MONTANTS ET CONSOLES | RAIL GUIDES AND BRACKETS

- 78** **Guías y cartelas** | Montants et consoles | Rail guides and brackets

EXPOSITORES/IMPLANTACIONES

EXPOSITEURS/IMPLANTATIONS

DISPLAYS AND IN-STORE CONCESSIONS

- 80** **Implantaciones Clips, escuadras decorativas y estantes de madera y cristal** | Implantations Clips, Équerres décoratives, tablettes en verre et bois | Implantations Locks clips, decorative brackets and wooden and glass shelves
- 89** **Implantaciones Guías y Cartelas** | Implantations Guides et supports | Implantations Guide rails and brackets

646 906 561
NUEVO SERVICIO CLIENTE
NOUVEAU SERVICE CLIENTELE
NEW CUSTOMER SERVICE



COMPANY WITH
QUALITY SYSTEM
ISO 9001

Escuadras de acero
Equerres d'acier
Steel brackets

EAN = 8421272 + Ref.

ROBUSTO



Prueba de resistencia realizada ante notario
Essai constaté par huissier de justice
Strength test undertaken before a notary

Alta resistencia | Haute résistance
Highly resistant

cm.	Kg MAX. RECOM. 2 UN. carga repartida charge répartie distributed load	Box	Color	
			Blanco Blanc White	Negro Noire Black
18 x 20	300	10	009560	009577
18 x 30	300	10	001267	001281
18 x 40	300	10	001274	001298
30 x 50	300	8	001182	001205



FORTEX



Alta resistencia | Haute résistance
Highly resistant

cm.	Kg MAX. RECOM. 2 UN. carga repartida charge répartie distributed load	Box	Color			Negro Noire Black
			Blanco Blanc White	Plata Argent Silver	Zinc Zinco	
20 x 25	300	5	009164	009188	009171	008983
20 x 30	300	5	009829	009881	009850	008952
25 x 40	240	5	009836	009898	009867	008969
33 x 50	200	5	009843	009904	009874	008976



NEW

FORTEX MINI



Alta resistencia | Haute résistance
Highly resistant

cm.	Kg MAX. RECOM. 2 UN. carga repartida charge répartie distributed load	Box	Color			Negro Noire Black
			Blanco Blanc White	Plata Argent Silver	Zinc Zinco	
10 x 15	240	10	008754	008778	008761	008785
12,5 x 20	240	10	007283	007368	007320	008792
15 x 25	240	10	007290	007375	007337	008808
17,5 x 30	300	10	007306	007382	007344	008815



NEW

Escuadras de acero plegables
 Equerres d'acier pliées
 Folding steel brackets

EAN = 8421272 + Ref.

ABAT-PLAN



Alta resistencia. 2 cm Plegada
Haute résistance. 2 cm pliées
Highly resistant. 2 cm folded



				Blanco Blanc White	Gris Plata Gris Argenté Silver Grey	Blanco Blanc White	Negro Noir Black
11 x 20	200	10	036023	036047			009973
16 x 30	200	10	036030	036054			009980
40 x 40	400	6	009935	009911	009959		009997
40 x 52	400	6	009942	009928	009966		010009



ABAT-TABLE



Alta resistencia. 2 cm Plegada
Haute résistance. 2 cm pliées
Highly resistant. 2 cm folded



				Blanco Blanc White	Gris Plata Gris Argenté Silver Grey	Blanco Blanc White	Negro Noir Black
30 X 40	300	6	015431	015455			015479
30 X 52	300	6	015448	015462			015486



Más espacio bajo la mesa
Plus d'espace sous la table
More space under the table

Nuevo diseño con travesaño más corto y que proporciona mayor espacio útil.
Nouveau desing avec barre transversale plus courte et offrant plus d'espace utile
desing with shorter crossbar and that provides more useful space.

Escuadras de acero
 Equerres d'acier
 Steel brackets

EAN = 8421272 + Ref.

FEPRE



A Granel | En vrac | Bulk

				Blanco Blanc White	Gris Plata Gris Argenté Silver Grey	Negro Noir Black	Bronceado Bricolage Bricomating
3 x 3	-	10	000239	004404	000673	000123	
5 x 5	80	10	000246	004411	000680	000130	
7,5 x 7,5	54	10	000253	004428	000697	000147	
10 x 10	50	10	000260	004435	000703	000154	
12,5 x 12,5	30	10	000277	004442	000710	000161	
12,5 x 16	100	8	000291	004459	000734	000185	
15 x 20	100	8	000307	004466	000741	000192	
20 x 28	180	8	000321	004473	000765	000215	



FEPRE



Blister 2/u

				Blanco Blanc White
3 x 3	-	6	010238	
5 x 5	80	6	010245	
7,5 x 7,5	54	6	010252	
10 x 10	50	6	010269	



Escuadras de acero
 Equerres d'acier
 Steel brackets

EAN = 8421272 + Ref.

DUNA



Alta resistencia. Tornillería incluida.
Haute résistance. Visserie comprise.
Highly resistant. Screws included.

			Blanco Blanc White	Negro Noire Black
10 x 15	30	10	016704	009706
15 x 20	30	10	016711	009713
15,5 x 25	30	10	016728	009720
20,5 x 30	30	10	016735	009737
20,5 x 34,5	40	10	016742	009744



NEW

ÓPTIMA



			Blanco Blanc White	Plata mate Argent mat Matt Silver	Negro Noire Black
12,5 x 15	70	10	004756	036306	004800
15 x 20	70	10	004763	036313	004817
20 x 25	60	10	004770	036320	004824
25 x 30	60	10	004787	036337	004831



NEW

Escuadras de acero
Equerres d'acier
Steel brackets

EAN = 8421272 + Ref.

PALOMILLA



Dimensions (cm)	Weight (kg)	Units per box	Blanco	Gris	Negro
			Blanc	Grey	Noire
			White	Grey	Black
7,5 x 10	50	20	001007	001083	039475
10 x 12,5	50	20	001014	001090	039482
12,5 x 15	60	20	001021	001106	039499
15 x 20	60	20	001038	001113	039505
17,5 x 22,5	40	20	001045	001120	046213
20 x 25	40	20	001052	001137	039512
25 x 30	60	20	001069	001144	039529
30 x 35	40	20	001076	001151	039536
35 x 40	56	10	001168	001328	046190
40 x 45	60	10	005838	005845	046206



NOON



Dimensions (cm)	Weight (kg)	Units per box	Blanco	Plata	Negro
			Blanc	Argent	Noire
			White	Silver	Black
15 x 15	200	10	004862	004923	004954
20 x 20	200	10	004879	004930	004961
25 x 25	200	10	004886	004947	004978



Escuadras de acero
 Equerres d'acier
 Steel brackets

EAN = 8421272 + Ref.

NOON L

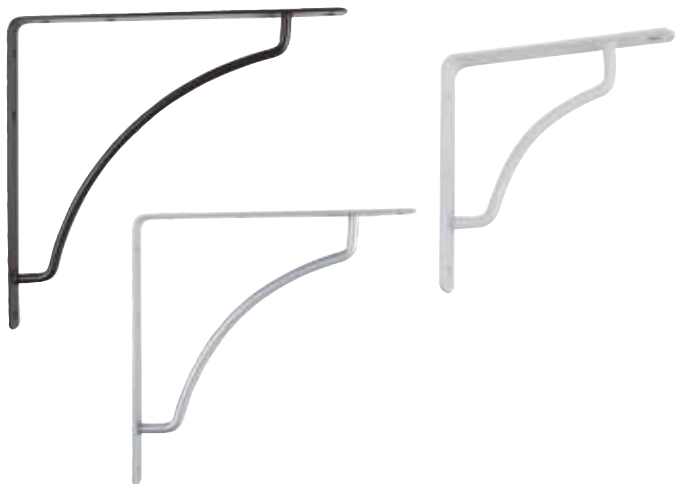

				Blanco Blanc White	Plata Argent Silver	Negro Noire Black
15 x 15	300	10		016285	016360	016407
20 x 20	300	10		016292	016377	016414
25 x 25	300	10		016308	016384	016421



Escuadras de acero infantiles
 Equerres d'acier infantiles
 Character steel brackets

ÓVALO



			Blanco Blanc White Bianco	Plata Argent Silver Argento
18 x 18 x 6	36		006699	006705



TRIANGULO



			Blanco Blanc White Bianco	Negro Noire Black Nero
18 x 18 x 6	16		006651	006996



Escudras de acero ornamentales
 Equerres d'acier ornementaux
 Ornamental steel brackets

EAN = 8421272 + Ref.



ORNAMENT

cm.	Kg Max. RECOM. 2 UN. carga repartida charge répartie distributed load	Box	Blanco Blanc White	Negro Noire Black
			005012	005050
10 x 10	100	10	005012	005050
15 x 15	140	10	005029	005067
20 x 20	140	10	005036	005074
25 x 25	160	10	005043	005081



FORJA

cm.	Kg Max. RECOM. 2 UN. carga repartida charge répartie distributed load	Box	Negro Noire Black	
				016209
20 x 25	120	10		016209
25 x 30	100	10		016216
30 x 35	60	10		016223
35 x 40	60	10		016230



FORJA PLANO

cm.	Kg Max. RECOM. 2 UN. carga repartida charge répartie distributed load	Box	Negro Noire Black	
				015059
9 x 10	20	10		015059
12,5 x 15	60	10		036245
15 x 20	100	10		036238
20 x 25	80	10		036252



Escuadras de madera
Equerres en bois
Wood brackets



EAN = 8421272 + Ref.



FORESTA P

cm.	Kg Max. peso 2 UN. carga repartida charge répartie distributed load carico distribuito		Haya Hêtre Beech
10 x 15	34	10	005500
15 x 20	26	10	005517
20 x 25	20	10	005524
25 x 30	12	10	005692



NO microondas
NON micro-ondes
NO microwave

FEPRE M

cm.	Kg Max. peso 2 UN. carga repartida charge répartie distributed load carico distribuito		Haya Hêtre Beech
11 x 14	60	10	005302
15 x 20	40	10	005326
20 x 25	50	10	005241
25 x 30	30	10	005258



RUSTIC

cm.	Kg Max. peso 2 UN. carga repartida charge répartie distributed load carico distribuito		Blanco Blanc White	Negro Noire Black	Haya Hêtre Beech	Nogal Noyer Walnut
17 x 23	150	10	047746	047715	005180	016650
23 x 28	160	10	047753	047722	005197	016667
28 x 32	160	10	047760	047739	005203	016674



ONDULADA

cm.	Kg Max. peso 2 UN. carga repartida charge répartie distributed load carico distribuito		Haya Hêtre Beech
13,5 x 15,5	80	10	016681
16,5 x 19,5	80	10	016698



Escuadras Decorativas de acero
Equerres Décoratives d'acier
 Steel decorative brackets

EAN = 8421272 + Ref.



NODE

cm.	Kg Max. peso 2 UN. carga repartida charge répartie distributed load	Box	Gris Gris Grey	Bronze ant. Bronze ant. Bronze ant.
14,5 x 14,5	40	6	045551	045537
19,5 x 19,5	40	6	045568	045544



AIRY

cm.	Kg Max. peso 2 UN. carga repartida charge répartie distributed load	Box	Negro Noire Black	Gris Gris Grey	Bronze ant. Bronze ant. Bronze ant.
14,5 x 14,5	12,5	6	045575	045599	045612
19,5 x 19,5	12,5	6	045582	045605	045629



STAIR

cm.	Kg Max. peso 2 UN. carga repartida charge répartie distributed load	Box	Plata mate Argent mat Matt Silver
14,5 x 14,5	30	6	045636
19,5 x 19,5	40	6	045643





Escuadras Decorativas de acero
Equerres Décoratives d'acier
 Steel decorative brackets

EAN = 8421272 + Ref.



Mini Curve

	 Kg. MAX. RECOM. 2 UN. carga repartida charge répartie distributed load		Blanco Blanc White	Plata mate Argent mat Matt Silver	Cromo Chrome Chrome
14 x 14	30	6	045667	045650	045674

Curve

	 Kg. MAX. RECOM. 2 UN. carga repartida charge répartie distributed load		Blanco Blanc White	Plata mate Argent mat Matt Silver	Negro Noire Black
24 x 24	40	6	045698	045681	045704



TUCSON

	 Kg. MAX. RECOM. 2 UN. carga repartida charge répartie distributed load		Blanco Blanc White	Negro Noire Black
15 x 20	10	6	015608	015639
15 x 25	10	6	015615	015646
15 x 30	10	6	015622	015653



ARMS

	 Kg. MAX. RECOM. 2 UN. carga repartida charge répartie distributed load		Blanco Blanc White	Negro Noire Black
20 x 18	10	6	015806	015813

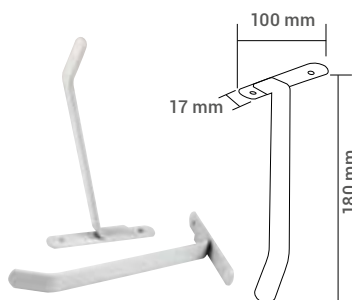

Soporte para repisa de radiador - 2/u.
Support pour tablette radiateur. 2/u.
Support for radiator shelf. Blister pack of 2/u.

	Blanco Blanc White
6	040204



Clips para estantes
Pincas pour tabletterie
Lock clips for shelves



EAN = 8421272 + Ref.



Soft Microclip

			Blanco Blanc White	INOX.	Plata mate Argent mat Matt Silver	Negro Noire Black
0,3 - 0,8	10	6	046084	046107	046091	046114

Soft Juniorclip

			Blanco Blanc White	INOX.	Plata mate Argent mat Matt Silver	Negro Noire Black
0,3 - 1,8	25	6	045964	045988	045971	045995

Soft Midiclip

			Blanco Blanc White	INOX.	Plata mate Argent mat Matt Silver	Negro Noire Black
0,4 - 2,8	30	6	046008	046022	046015	046039

Soft Seniorclip

			Blanco Blanc White	INOX.	Plata mate Argent mat Matt Silver	
0,4 - 4,2	60	6	046046	046060	046053	

Estantes de MDF preperforados
Tablettes en MDF prépercées
MDF shelves pre holed

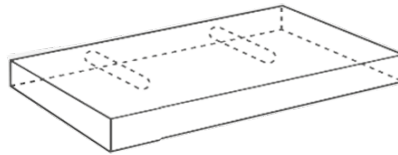

EAN = 8421272 + Ref.

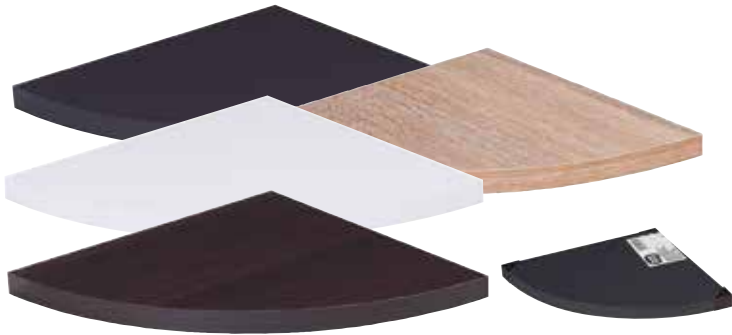

RINCONERA | D'ANGLE | CORNER SHELF

		1,8	1,8	1,8	1,8
		Blanco Blanc White	Wenge	Roble Blanco Chêne Blanc Oak	Antracita Anthracite
25 x 25	3	038508	038560	017183	017152



RONDO | RONDO | RONDO

		1,8	1,8	1,8	1,8
		Blanco Blanc White	Wenge	Roble Blanco Chêne Blanc Oak	Antracita Anthracite
60 x 25	3	038737	038874	017442	017404
80 x 25	3	038751	038898	017459	017411



RECTANGULAR | RECTANGULAIRE | RECTANGULAR

		1,8	1,8	1,8	1,8
		Blanco Blanc White	Wenge	Roble Blanco Chêne Blanc Oak	Antracita Anthracite
60 x 15	3	038584	038690	017428	017381
60 x 25	3	038591	038706	017190	017169
80 x 15	3	038607	038997	017435	017398
80 x 25	3	038614	038713	017206	017176



SOFT CLAMP

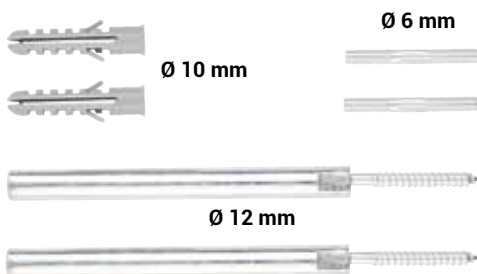
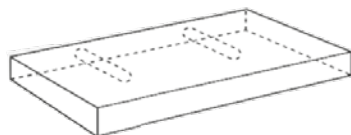

Soportes de fijación invisible
Supports de fixation invisible
Invisible fastening brackets

		1,2	10	6	047586
		Ø		ALU	
12 x 12	1,2	10	6	047586	



Estantes Tamborados HD. Fijación invisible
 Tablette alvéolaire HD. Fixation invisible
 HD hollow core shelves. Floating



EAN = 8421272 + Ref.

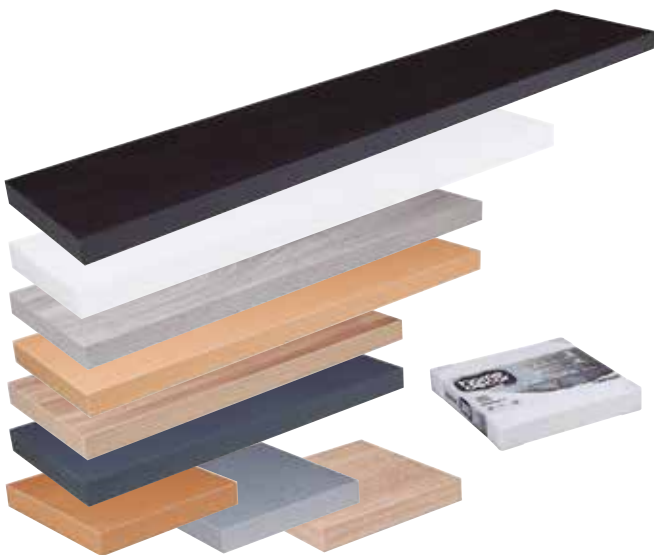

Tornillos de fijación a pared no incluidos. Vis de fixation au mur pas inclus. Fixing screw wall not included.

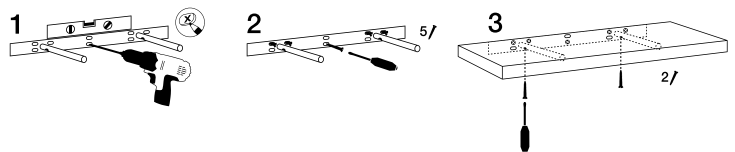

Estantes Tamborados HD. Acabado de PVC | Tablette alvéolaire HD. Finition PVC
 HD hollow core shelves. PVC coating

			4	4	4	4	4	4	4	4	4
			Blanco Blanc White	ALU	Antracita Anthracite Anthracite	Haya Hêtre Beech	Roble Chêne Oak	Roble blanco Chêne blanc Oak	Roble gris Chêne gris Gray oak	Roble viejo Chêne vieux Old oak	Wenge
25 x 25	5	3	046312	047470	017213	045063	045179	047678	047777	047807	045247
60 x 25	25	3	045315	045216	017220	045070	045186	047685	047784	047814	045254
80 x 25	25	3	045322	045223	017237	045087	045193	047692	047791	047821	045261
120 x 25	25	3	046329	045230	017305	045094	045209	017312	017329	017336	045278
60 x 20	25	3	005807								
80 x 20	25	3	045858								



Estantes Tamborados HD. Fijación invisible
 Tablette alvéolaire HD. Fixation invisible
 HD hollow core shelves. Floating



EAN = 8421272 + Ref.



JUNIOR

Acabado en PVC | Finition PVC | PVC coating

		4				
		cm				
			Blanco Blanc White	Negro Noire Black	Roble blanco Chêne blanc Oak	Wenge
30 x 15	5	3	037464	037518	017343	037495



LACADOS

Estantes lacados | Tablettes laquées | Shelves lacquered

		4		
		cm		
			Blanco Blanc White	
25 x 25	5	3	045438	
60 x 25	25	3	045445	
80 x 25	25	3	045452	
120 x 25	25	3	045469	



U RECTO

Lacado | Laquée | Lacquered

		2			
		cm			
			Blanco Blanc White	Negro Noire Black	Wenge PVC
60 x 10 x 15	10	3	037105	047593	037112



Sujetalibros | Serre-livres | Bookends

		3,8	
		cm	
		Gris Grey Griego	
60 x 19	5	041539	





EAN = 8421272 + Ref.

Estantes Tamborados HD. Fijación invisible
 Tablette alvéolaire HD. Fixation invisible
 HD hollow core shelves. Floating



ZIG ZAG

Acabado de PVC | Finition PVC
 PVC coating

 cm	carga repartida charge répartie distributed load	1,8	1,8	1,8	1,8
		Blanco Blanc White	Negro Noir Black	Roble blanco Chêne blanc Oak	Wenge
59 x 12 x 12	10	037372	047395	017374	037396



CANTOS REDONDOS

Estantes con cantos redondos. Recubrimiento de PVC
 Bords arrondis. Finition PVC
 Rounded-edge shelves. PVC coating

 cm	carga repartida charge répartie distributed load		4
			Blanco Blanc White
60 x 25	25	3	037525
80 x 25	25	3	037402



Estante metálico | Tablette métallique | Metal shelf

 cm	carga repartida charge répartie distributed load		1,2	1,2
			Blanco Blanc White	Negro Noir Black
60 x 18	-	1	810682	810675



APERTO

Cajonera | Commode | Chest of drawers

 cm	carga repartida charge répartie distributed load		Blanco/Roble Blanc/Chêne White/Oak	Negro/Roble Noir/Chêne Black/Oak
			40 x 30 x 20	-





EAN = 8421272 + Ref.

Estantes HD. Fijación invisible
 Tablette HD. Fixation invisible
 HD floating shelves

TRIPLE CUBO RECTO. Acabado de PVC | Finition PVC | PVC coating



			1,2	1,2	1,2	1,2	1,2	1,2	1,2	1,2	1,2
	Kg Max. peso 2 UN. carga repartida charge répartie distributed load		Blanco Blanc White	ALU	Antracita Anthracite Anthraxite	Negro Noire Black	Roble Chêne Oak	Roble blanco Chêne blanc Oak	Roble gris Chêne gris Gray oak	Roble viejo Chêne vieux Old oak	Wenge
30 x 30 x 12	5	3									
27 x 27 x 12	5	3	045810	047364	017268	047371	045803	047708	017244	017251	045957
24 x 24 x 12	5	3									



TRIPLE CUBO RECTANGULAR



**Acabado de PVC | Finition PVC
 PVC coating**

			1,2	1,2
	Kg Max. peso 2 UN. carga repartida charge répartie distributed load		Blanco Blanc White	Roble blanco Chêne blanc Oak
30 x 60 x 15	5	2		
26,5 x 38 x 15	5	2	047388	017275
26,5 x 17 x 15	5	2		



TRIPLE CUBO RONDO



Lacado | Laquée | Lacquered

			1,5	1,5
	Kg Max. peso 2 UN. carga repartida charge répartie distributed load		Blanco Blanc White Blanco	Negro Noire Black Nero
30 x 30 x 10	5	3		
25 x 25 x 10	5	3	037037	036948
20 x 20 x 10	5	3		



LACADO
 LAQUÉ
 LAQUERED



EAN = 8421272 + Ref.

COMBISYSTEM. Guías y cartelas
COMBISYSTEM. Consoles et crémaillères
COMBISYSTEM. Rail guides and brackets

SISTEMA 50
SYSTÈME 50
SYSTEM 50





Cartelas simples | Consoles simples
Single brackets

Dim. cm	 Pkg. MAX. RECOM. 2 UN. carga repartida charge répartie distributed load		Blanco	Plata	Negro
			Blanc	Argent	Noire
			White	Silver	Black
15	40	20	038102	038171	037938
20	40	20	038119	038188	037945
25	40	20	038126	038195	037952
30	40	20	038133	038201	037969
35	40	20	038140	038218	037976
40	40	20	038157	038225	037983
50	40	10	038164	038232	037990



Cartelas dobles | Consoles doubles
Double brackets

Dim. cm	 Pkg. MAX. RECOM. 2 UN. carga repartida charge répartie distributed load		Blanco	Plata	Negro
			Blanc	Argent	Noire
			White	Silver	Black
17	55	10	038003	038058	037884
22	55	10	038010	038065	037891
27	55	10	038027	038072	037907
37	55	10	038034	038089	037914
47	55	10	038041	038096	037921



EAN = 8421272 + Ref.

COMBISYSTEM. Guías y cartelas
COMBISYSTEM. Consoles et crémaillères
COMBISYSTEM. Rail guides and brackets



SISTEMA 50
SYSTÈME 50
SYSTEM 50

NEW

Guías simples. Packs de 2/u
Crémaillères simples Pack 2/u
Single rail guides. Packs of 2 guides

Dim. cm		Blanco Blanc White	Plata Argent Silver	Negro Noire Black
50	6 pack de 2	038324	038362	038447
100	6 pack de 2	038331	038379	038454
150	6 pack de 2	038348	038386	038461
200	6 pack de 2	038355	038393	038478



NEW

Guías dobles. Packs de 2/u
Crémaillères doubles Pack 2/u
Double rail guides. Packs of 2 guides

Dim. cm		Blanco Blanc White	Plata Argent Silver	Negro Noire Black
50	6 pack de 2	038249	038287	038409
100	6 pack de 2	038256	038294	038416
150	6 pack de 2	038263	038300	038423
200	6 pack de 2	038270	038317	038430



Expositores/Implantaciones
 Expositeurs/Implantations
 Displays and In-store concessions



IMPLANTACIÓN ESCUADRAS
IMPLANTATION ÉQUERRES
BRACKETS IMPLANTATION

Ref. E-2.

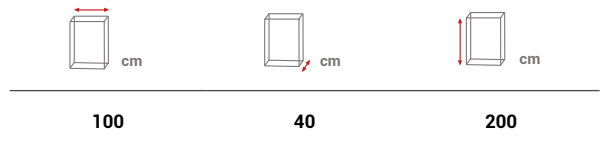

Góndola y panel no incluidos | Gondole et panneau pas compris.
 Stand and panel non included

Hacemos implantaciones a medida ¡CONTACTANOS!
 Nous réalisons implantations personnalisées CONTACTEZ-NOUS !
 We do customised implantations CONTACT US!



Expositores/Implantaciones
 Expositeurs/Implantations
 Displays and In-store concessions



IMPLANTACIÓN ESCUADRAS
IMPLANTATION ÉQUERRES
BRACKETS IMPLANTATION

Ref. E-3.



130

40

200

Góndola y panel no incluidos | Gondole et panneau pas compris.
 Stand and panel non included

Hacemos implantaciones a medida ¡CONTACTANOS!
 Nous réalisons implantations personnalisées CONTACTEZ-NOUS !
 We do customised implantations CONTACT US!



Expositores/Implantaciones
 Expositeurs/Implantations
 Displays and In-store concessions



IMPLANTACIÓN ESCUADRAS
IMPLANTATION ÉQUERRES
BRACKETS IMPLANTATION

Ref. E-4.

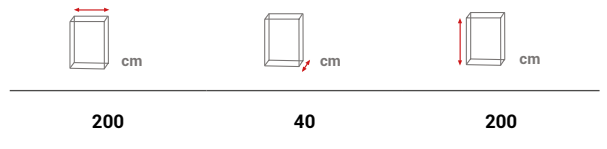

Góndola y panel no incluidos | Gondole et panneau pas compris.
 Stand and panel non included

Hacemos implantaciones a medida ¡CONTACTANOS!
 Nous réalisons implantations personnalisées CONTACTEZ-NOUS !
 We do customised implantations CONTACT US!





Expositores/Implantaciones
 Expositeurs/Implantations
 Displays and In-store concessions

IMPLANTACIÓN ESTANTES DE MADERA Y SOPORTES
IMPLANTATION D'ÉTAGÈRES EN BOIS ET SUPPORTS
INSTALLATION OF SHELVES OF WOOD AND SUPPORTS

Ref. HD1-1.

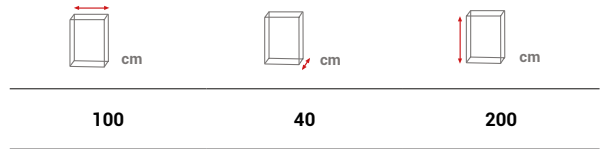

- Góndola no incluida. Tijas para estantes y cartelería incluidas.
- Gondole pas compris. Broches pour tablettes et affichage compris.
- Stand not included. Hocks for shelves and panel included.

Hacemos implantaciones a medida ¡CONTACTANOS!
 Nous réalisons implantations personnalisées CONTACTEZ-NOUS !
 We do customised implantations CONTACT US!



Expositores/Implantaciones
 Expositeurs/Implantations
 Displays and In-store concessions



IMPLANTACIÓN ESTANTES DE MADERA Y SOPORTES
IMPLANTATION D'ÉTAGÈRES EN BOIS ET SUPPORTS
INSTALLATION OF SHELVES OF WOOD AND SUPPORTS

Ref. HD1-2.

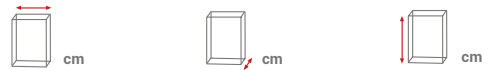

130 40 200

- Góndola no incluida. Tijas para estantes y cartelería incluidas.
- Gondole pas compris. Broches pour tablettes et affichage compris.
- Stand not included. Hocks for shelves and panel included.

Hacemos implantaciones a medida ¡CONTACTANOS!
 Nous réalisons implantations personnalisées **CONTACTEZ-NOUS !**
 We do customised implantations **CONTACT US!**



Expositores/Implantaciones
 Expositeurs/Implantations
 Displays and In-store concessions



IMPLANTACIÓN ESTANTES DE MADERA Y SOPORTES
IMPLANTATION D'ÉTAGÈRES EN BOIS ET SUPPORTS
INSTALLATION OF SHELVES OF WOOD AND SUPPORTS

Ref. HD1-3.

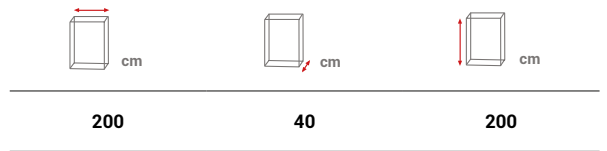

- Góndola no incluida. Tijas para estantes y cartelería incluidas.
- Gondole pas compris. Broches pour tablettes et affichage compris.
- Stand not included. Hocks for shelves and panel included.

Hacemos implantaciones a medida ¡CONTACTANOS!
 Nous réalisons implantations personnalisées CONTACTEZ-NOUS !
 We do customised implantations CONTACT US!



Expositores/Implantaciones
 Expositeurs/Implantations
 Displays and In-store concessions



**IMPLANTACIÓN ESTANTES
 DE FIJACIÓN INVISIBLE**
TABLETTES DE FIXATION INVISIBLE
INVISIBLE FIXING SHELVES

Ref. HD2-1.

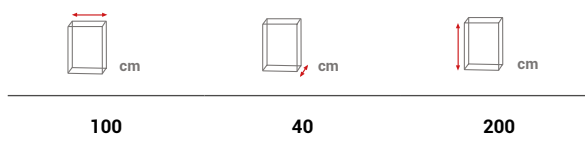

- Góndola no incluida. Tijas para estantes y cartelería incluidas.
- Gondole pas compris. Broches pour tablettes et affichage compris.
- Stand not included. Hocks for shelves and panel included.

Hacemos implantaciones a medida ¡CONTACTANOS!
 Nous réalisons implantations personnalisées CONTACTEZ-NOUS !
 We do customised implantations CONTACT US!

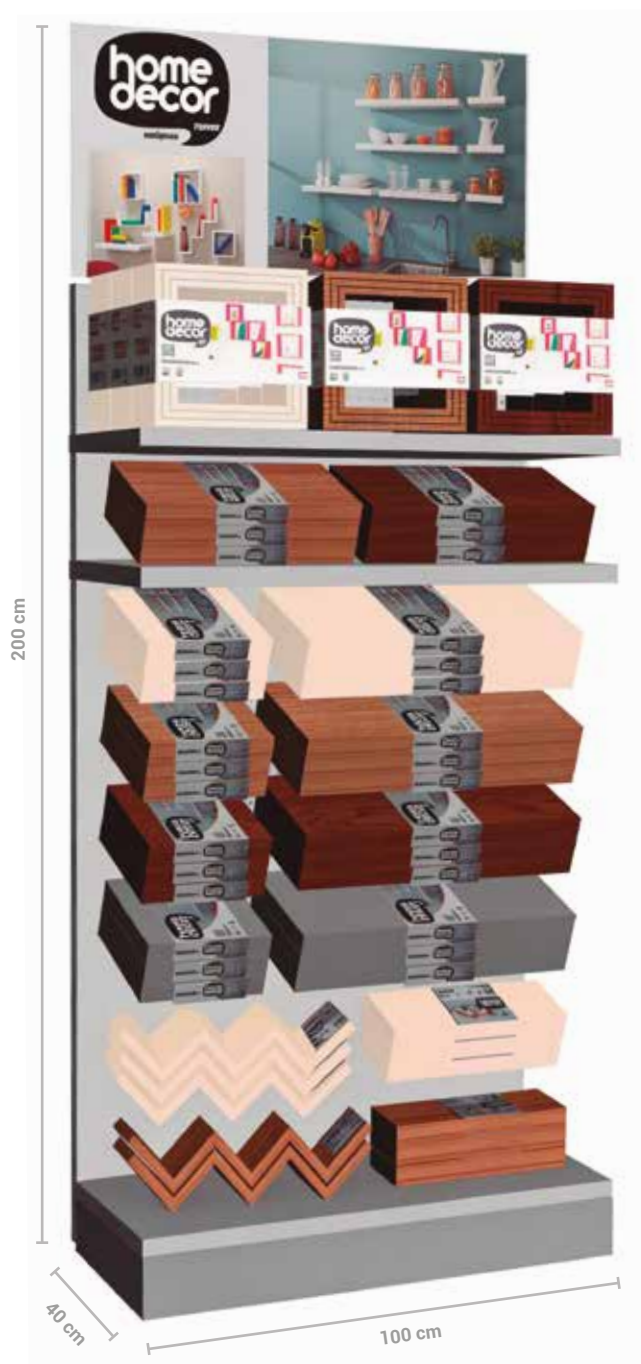

Expositores/Implantaciones
 Expositeurs/Implantations
 Displays and In-store concessions



IMPLANTACIÓN ESTANTES DE FIJACIÓN INVISIBLE
TABLETTES DE FIXATION INVISIBLE
INVISIBLE FIXING SHELVES

Ref. HD2-2.

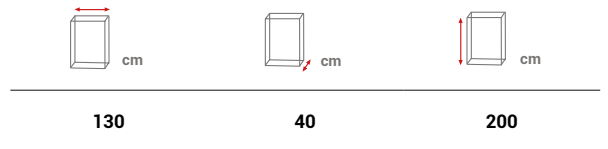

- Góndola no incluida. Tijas para estantes y cartelería incluidas.
- Gondole pas compris. Broches pour tablettes et affichage compris.
- Stand not included. Hocks for shelves and panel included.

Hacemos implantaciones a medida ¡CONTÁCTANOS!
 Nous réalisons implantations personnalisées CONTACTEZ-NOUS !
 We do customised implantations CONTACT US!



Expositores/Implantaciones
 Expositeurs/Implantations
 Displays and In-store concessions



IMPLANTACIÓN ESTANTES DE FIJACIÓN INVISIBLE
TABLETTES DE FIXATION INVISIBLE
INVISIBLE FIXING SHELVES

Ref. HD2-3.



200 40 200

- Góndola no incluida. Tijas para estantes y cartelería incluidas.
- Gondole pas compris. Broches pour tablettes et affichage compris.
- Stand not included. Hocks for shelves and panel included.

Hacemos implantaciones a medida ¡CONTACTANOS!
 Nous réalisons implantations personnalisées CONTACTEZ-NOUS !
 We do customised implantations CONTACT US!

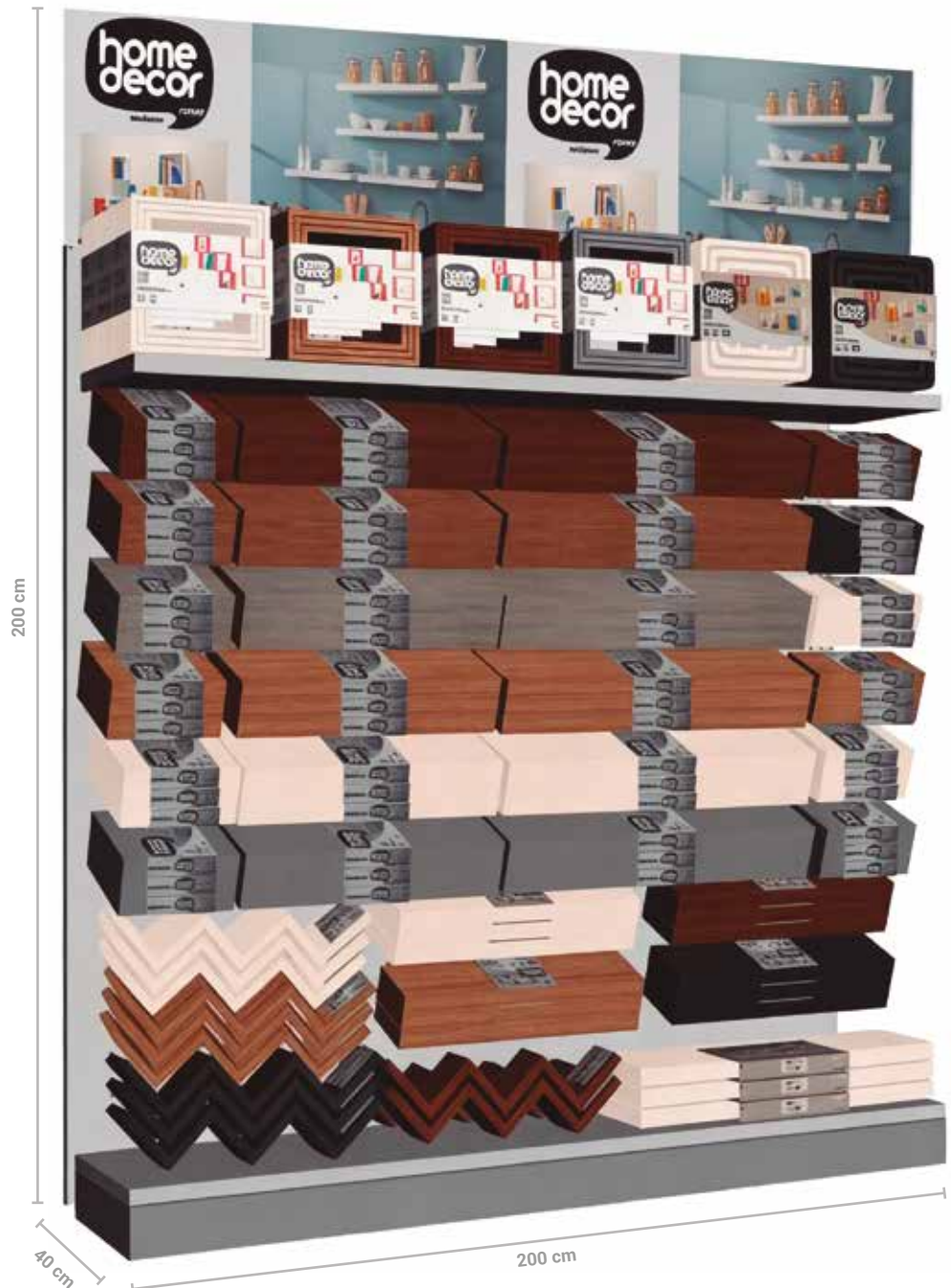

Expositores/Implantaciones
 Expositeurs/Implantations
 Displays and In-store concessions

CombiSystem

IMPLANTACIÓN COMBI-SYSTEM
IMPLANTATION COMBI-SYSTEM
COMBI-SYSTEM CONCESSION

Ref. CS-1 MIX. Simple & Doble.



100 40 200

- Góndola no incluida. Cartelería incluida.
- Gondole pas compris Affichage compris.
- Stand non included. Panel included.

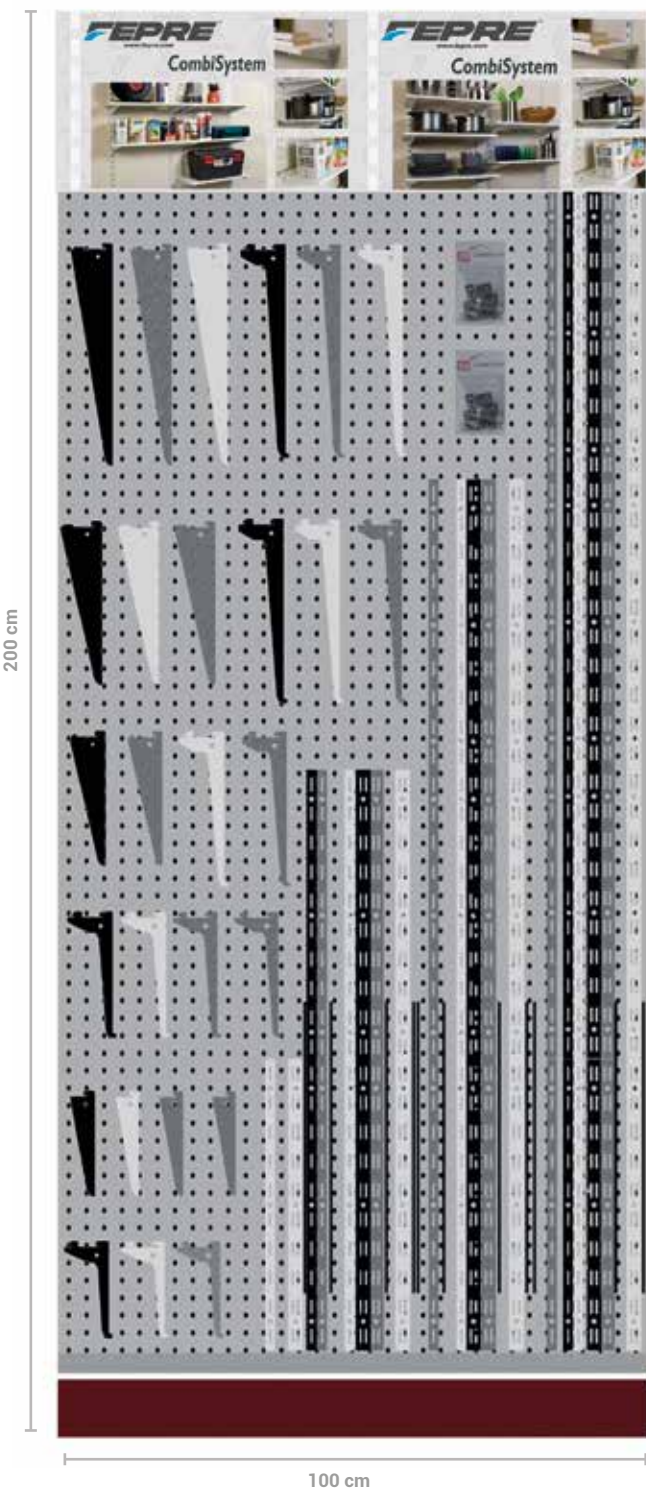

Guías y cartelas
 Formato simple & doble

Montants et consoles
 Format simple & double

Rails and brackets,
 Simple and double formats

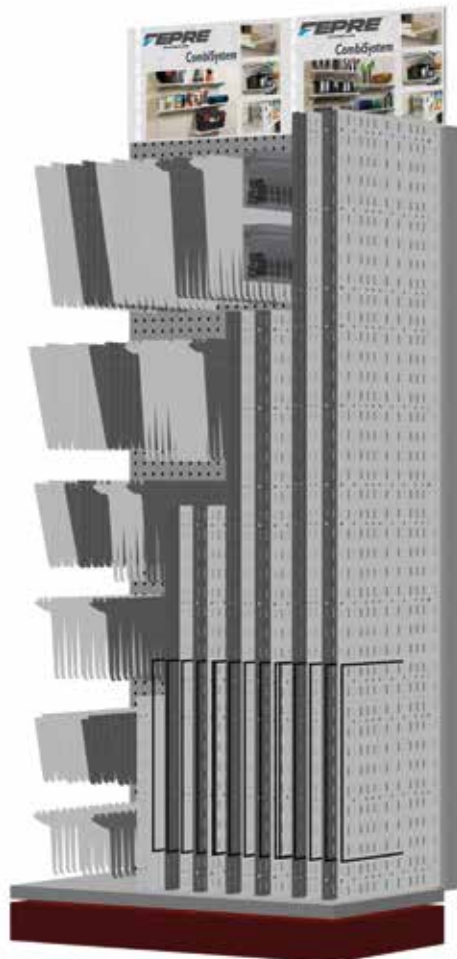

Expositores/Implantaciones
 Expositeurs/Implantations
 Displays and In-store concessions

CombiSystem

IMPLANTACIÓN COMBI-SYSTEM
IMPLANTATION COMBI-SYSTEM
COMBI-SYSTEM CONCESSION

Ref. CS-13 MIX. Simple & Doble.



130

40

200

- Góndola no incluida. Cartelería incluida.
- Gondole pas compris Affichage compris.
- Stand non included. Panel included.



Guías y cartelas
Formato simple & doble

Montants et consoles
Format simple & double

Rails and brackets,
 Simple and double formats

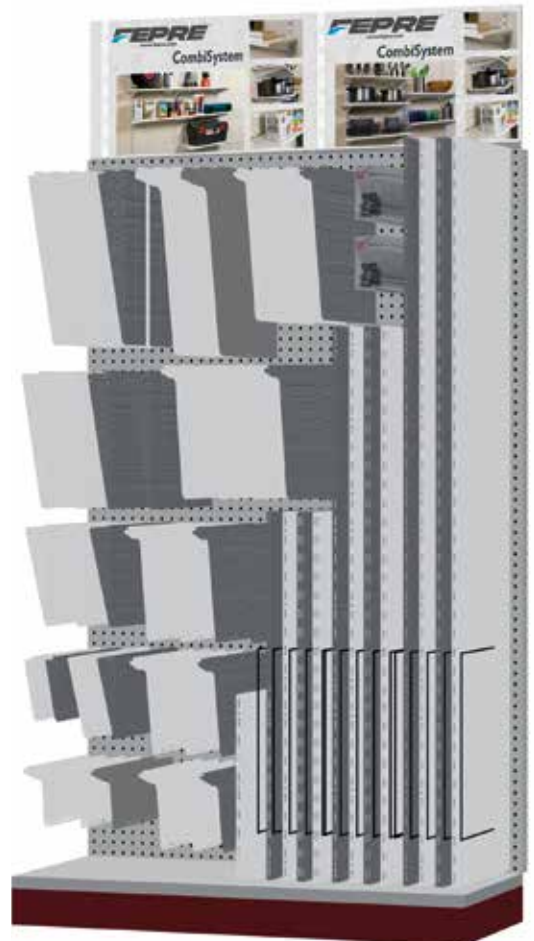
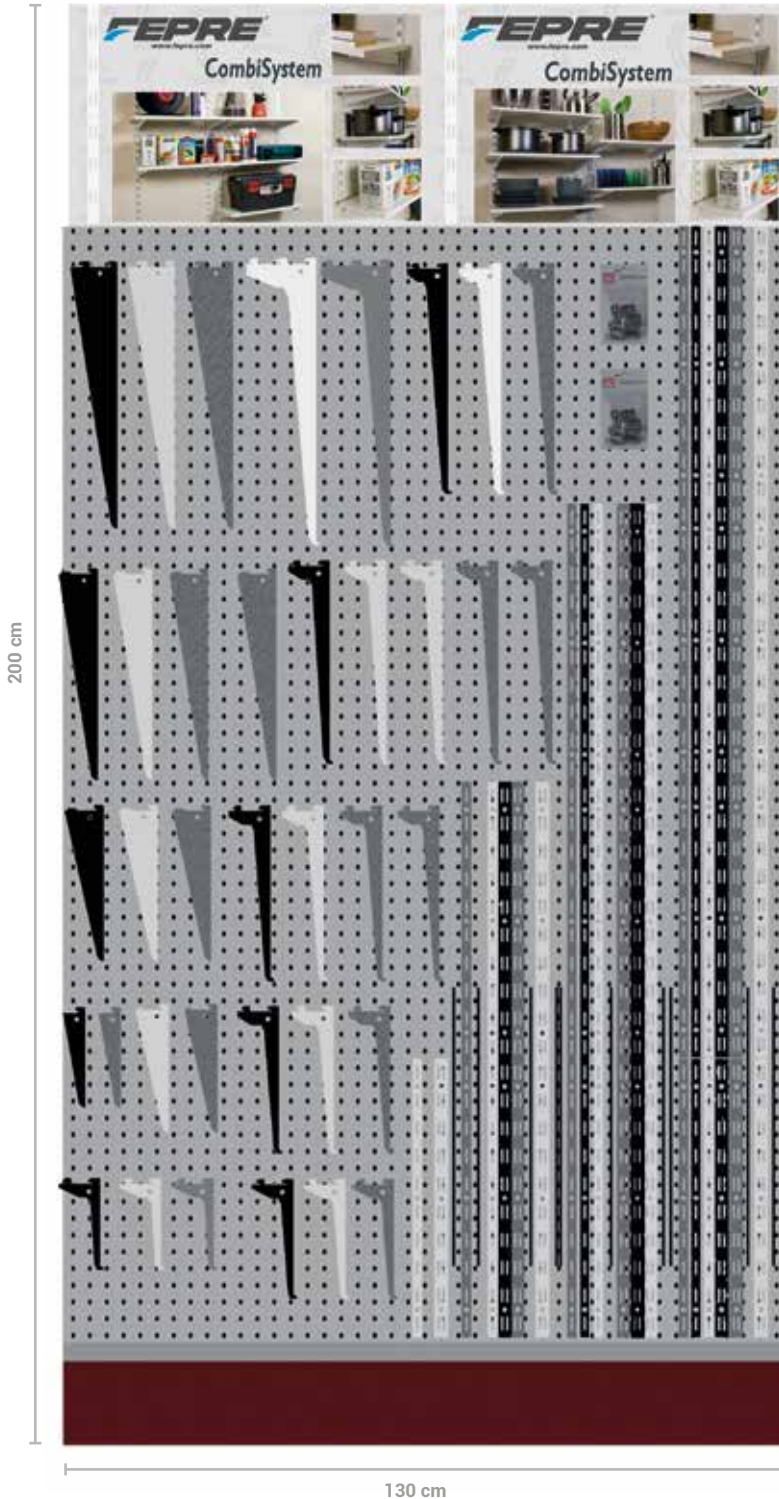

Expositores/Implantaciones
 Expositeurs/Implantations
 Displays and In-store concessions

CombiSystem

IMPLANTACIÓN COMBI-SYSTEM
IMPLANTATION COMBI-SYSTEM
COMBI-SYSTEM CONCESSION

Ref. CS-D. Doble.

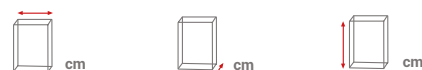

65

40

200

- Expositor y panel incluidos.
- Présentoir et affichage compris.
- Displays and panel included.

EXPOSITOR INCLUIDO
EXPOSANT INCLUS
EXHIBITOR INCLUDED



Guías y cartelas
Formato simple & doble

Montants et consoles
Format simple & double

Rails and brackets,
 Simple and double formats

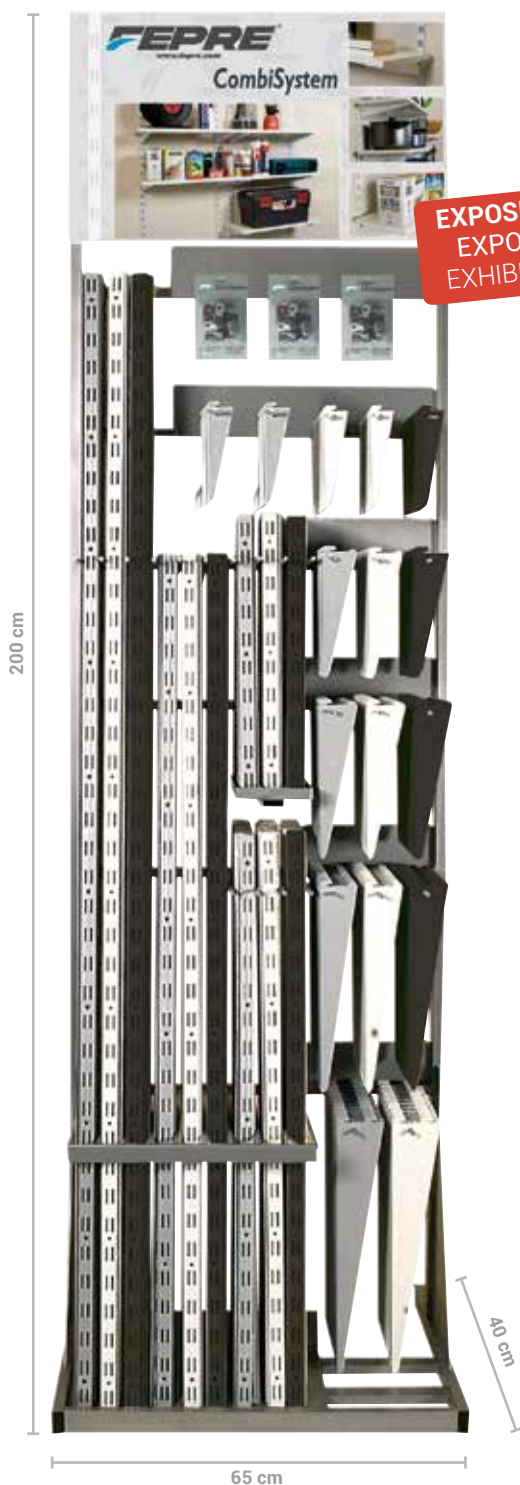

Expositores/Implantaciones
 Expositeurs/Implantations
 Displays and In-store concessions

CombiSystem

IMPLANTACIÓN COMBI-SYSTEM
IMPLANTATION COMBI-SYSTEM
COMBI-SYSTEM CONCESSION

Ref. CS-S. Simple.



65

40

200

- Expositor y panel incluidos.
- Présentoir et affichage compris.
- Displays and panel included.



EXPOSITOR INCLUIDO
EXPOSANT INCLUS
EXHIBITOR INCLUDED

Guías y cartelas
Formato simple & doble

Montants et consoles
Format simple & double

Rails and brackets,
 Simple and double formats

HOGAR MAISON HOME

PANELES | PANNEAUX | PANELS |

94 PanelTech | Paneltech | PanelTech

SOPORTES | SUPPORTS | BRACKETS |

98 Soportes TV | Supports TV | TV Supports

103 Soportes microondas | Supports micro-ondes |
Microwave brackets

TENDEROS | SECHOIRS | DRYING

104 Tenderos extensibles | Sechoirs a ligne extensibles |
Drying area extensibles | Stendibiancheria stensibile

FRIGOCASE

105 Organizadores para nevera | Organismateurs pour
frigo | Fridge organizers

PUERTAS | PORTES | GATES

106 Compuertas para animales | Portes pour petits
animaux | gate for small domestic animals

107 Compuertas para mascotas Amartdoor | Porte pour
connectée pour animaux SmartDoor | Smartdoor
connectec pet door

108 Tapas de registro | Trappes de visite | Revision hatch
door

GANCHOS | CROCHETS | HOOKS

109 Paneles perforados | Panneaux perforés | Perforated
panels

112 Multifuncionales | multifonctionnels | Multifunctional

113 Ganchos y soportes para bicicletas, patinetes y
monopatines | Crochets et supports pour vélos,
trottinettes et planches à roulettes | Hooks and
holders for bicycles, scooters and skateboards |

VEHICULO | VOITURE | VEHICLE

116 Protectores parking | Protecteurs de parking |
Parking protectors

COCINA | CUISINE | KITCHEN

120 Filtros de campana | Filtres de la hotte |
Hood filters

EXPOSITORES/IMPLANTACIONES

EXPOSITEURS/IMPLANTATIONS

DISPLAYS AND IN-STORE CONCESSIONS

646 906 561
NUEVO SERVICIO CLIENTE
NOUVEAU SERVICE CLIENTELE
NEW CUSTOMER SERVICE



COMPANY WITH
QUALITY SYSTEM
ISO 9001

PanelTech
PanelTech
PanelTech



EAN = 8421272 + Ref.

PANELES Y LOSETAS DECORATIVAS

PANNEAUX ET TUILES DÉCORATIFS | DECORATIVE PANELS AND TILES

La gama decorativa que combina diseño, calidad y valor añadido al punto de venta

La gamme décorative qui allie design, qualité et valeur ajoutée au point de vente

The decorative range that combines design, quality and added value at the point of sale

PANELTECH EASY



¡Instalación instantánea sin herramientas!
Installation instantanée sans outils!
Instant installation without tools!



PANELES ADHESIVOS

PANNEAUX ADHÉSIFS | ADHESIVE PANELS

PREPARADOS PARA REFORMAS | SE PRÉPARER AUX RÉFORMES | PREPARING FOR REFORMS



LIMPIA
NETTOIE
CLEAN



MIDE
MESURE
MEASURES



DESPEGA
DÉCOLLE
TAKES OFF



PEGA Y PRESIONA
TAPE ET APPUIE
STICK AND PRESS

PANELTECH ADVANCE

¡Listo para crear ambientes únicos!
prêt à créer des environnements uniques!
Ready to create unique environments!



LISTONES EN MDF

LAMES EN MDF | STRIPS IN MDF

ROBLE SOBRE FIELTRO NEGRO | CHÊNE SUR FEUTRE NOIR | OAK ON BLACK FELT



ACÚSTICO
ACOUSTIQUE
ACOUSTIC



CONEXIÓN INVISIBLE
CONEXIÓN INVISIBLE
INVISIBLE CONNECTION



RECORTABLE
DÉCOUPE
CUT-OUT



INSTALACIÓN FÁCIL
INSTALLATION FACILE
EASY INSTALLATION



RETARDO EN LA COMBUSTIÓN
RETARDEMENT DANS LA COMBUSTION
RETARDATION IN COMBUSTION

PanelTech Easy
PanelTech Easy
PanelTech Easy



EAN = 8421272 + Ref.



Rollos adhesivos de 58 x 300 cm
Rouleaux adhésifs de 58 x 300 cm
Adhesive rolls 58 x 300 cm



- 1 LIMPIA NETTOIE CLEAN
- 2 MIDE MESURE MEASURES
- 3 DESPEGA DÉCOLLE TAKES OFF
- 4 PEGA Y PRESIONA TAPE ET APPUÏE STICK AND PRESS

Rollos adhesivos Panneaux adhésifs Adhesive rolls

A x B	Roble Chêne Oak	Roble Gris Chêne Gris Oak gray
58 x 300	300537	300544



- Opción de entrega en Box Palet para una exposición atractiva y organizada en tienda.
- Instalación adhesiva. Los paneles se adhieren fácilmente a la pared.
- Fácil y rápida instalación sin herramientas.
- Fabricado en PVC 3D ultrarresistente, protegiendo la pared. Confort acústico.
- Disponible en 3 colores: roble Natural o roble Gris.
- Option de livraison en Box Palet pour une exposition attrayante et organisée en magasin.
- Installation adhésive. Les panneaux adhèrent facilement au mur.
- Installation facile et rapide sans outils.
- Fabriqué en PVC 3D ultra-résistant, protégeant le mur. Confort acoustique.
- Disponible en 3 couleurs : chêne naturel ou chêne gris.
- Box Palet delivery option for an attractive and organized in-store display
- Adhesive installation. The panels adhere easily to the wall.
- Easy and quick installation without tools.
- Made of ultra-resistant 3D PVC, protecting the wall. Acoustic comfort.
- Available in 3 colors: natural oak or gray oak.

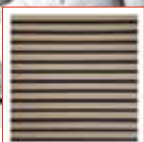

Losetas adhesivas de 58 x 58 cm
Plaques adhésives de 58 x 58 cm
Adhesive tiles of 58 x 58 cm



Losetas adhesivas Carreaux adhésifs Adhesive tiles

A x B	Roble Chêne Oak	Roble Gris Chêne Gris Oak gray
58 x 58	300506	300513



- Opción de entrega en Box Palet para una exposición atractiva y organizada en tienda.
- Instalación adhesiva. Los paneles se adhieren fácilmente a la pared.
- Fácil y rápida instalación sin herramientas.
- Fabricado en PVC 3D ultrarresistente, protegiendo la pared. Confort acústico.
- Disponible en 3 colores: roble Natural o roble Gris.
- Option de livraison en Box Palet pour une exposition attrayante et organisée en magasin.
- Installation adhésive. Les panneaux adhèrent facilement au mur.
- Installation facile et rapide sans outils.
- Fabriqué en PVC 3D ultra-résistant, protégeant le mur. Confort acoustique.
- Disponible en 3 couleurs : chêne naturel ou chêne gris.
- Box Palet delivery option for an attractive and organized in-store display.
- Adhesive installation. The panels adhere easily to the wall.
- Easy and quick installation without tools.
- Made of ultra-resistant 3D PVC, protecting the wall. Acoustic comfort.
- Available in 3 colors: natural oak or gray oak.

CONSULTA EL VIDEO PARA LA CORRECTA INSTALACIÓN
CONSULTEZ LA VIDÉO POUR L'INSTALLATION CORRECTE
CHECK THE VIDEO FOR THE CORRECT INSTALLATION



PanelTech Advance
PanelTech Advance
PanelTech Advance



EAN = 8421272 + Ref.



ACÚSTICO
ACOUSTIC



CONEXIÓN INVISIBLE
INVISIBLE CONNECTION



RECORTABLE
DÉCOUPE
CUT-OUT



INSTALACIÓN FÁCIL
EASY INSTALLATION



RETARDO EN LA COMBUSTIÓN
RETARDATION DANS LA COMBUSTION
RETARDATION IN COMBUSTION

Listones decorativos en MDF Lamelles décoratives en MDF Decorative strips in MDF



240 x 32

Roble
Chêne
Oak

300568



- Listones en MDF con acabado roble sobre fieltro negro. Panel mural para uso interior.
- Lamelles en MDF avec finition chêne sur feutre noir. Panneau mural pour usage intérieur.
- Strips in MDF with oak finish on black felt. Wall panel for interior use.

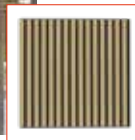

Losetas decorativas en MDF Carreaux décoratifs en MDF Decorative MDF tiles



60 x 60

Roble
Chêne
Oak

300575



- Losetas en MDF con acabado roble sobre fieltro negro. Panel mural para uso interior.
- Carreaux en MDF avec finition chêne sur feutre noir. Panneau mural pour usage intérieur.
- Tiles in MDF with oak finish on black felt. Wall panel for interior use.



Set 2 piezas
Set 2 pieces
Set 2 pieces

PROMOCIÓN
PROMOTION
PROMOTION

Listones decorativos en MDF. Set 2 piezas Lamelles décoratives en MDF. Set 2 pieces Decorative strips in MDF. Set 2 pieces



240 x 28

Roble
Chêne
Oak

300582



- Listones en MDF con acabado roble sobre fieltro negro. Panel mural para uso interior.
- Lamelles en MDF avec finition chêne sur feutre noir. Panneau mural pour usage intérieur.
- Strips in MDF with oak finish on black felt. Wall panel for interior use.

- Acabado profesional en chapa de madera de roble de alta calidad.
- Fielto de poliéster de alta densidad (9 mm ≈ 190 kg/m³).
- Con Paneltech gama Advance la distancia entre lama y lama es de 10 mm de distancia.
- Disponible en 3 colores:
roble Natural, roble Gris o roble Ahumado.

- Finition professionnelle en tôle de bois de chêne haute qualité.
- Feutre de polyester haute densité (9 mm 190 kg/m³).
- Avec la gamme Paneltech Advance, la distance entre les lames et lama est à 10 mm de distance.
- Disponible en 3 couleurs :
chêne naturel, chêne gris ou chêne fumé.

- Professional finish in high oak wood veneer quality.
- High-density polyester felt (9 mm 190 kg/m³).
- With Paneltech Advance range the distance between blades and lama is 10 mm apart.
- Available in 3 colours:
natural oak, grey oak or smoked oak.

PanelTech Advance
PanelTech Advance
PanelTech Advance



EAN = 8421272 + Ref.

Estante metal negro | Étagère en métal noir | Black metal shelf



	Negro Noir Black
A x B	
13 x 60	811146

Percha metal negro | Perche métal noir | Black metal perch



	Negro Noir Black
A x B	
19 x 4	811184

Percha metal madera FSC | Perche en métal bois FSC | FSC wooden metal stand



Ø cm	Negro Noir Black	Haya Hêtre Beech
8	811160	811153

Placa metal negro | Plaque en métal noir | Black metal plate

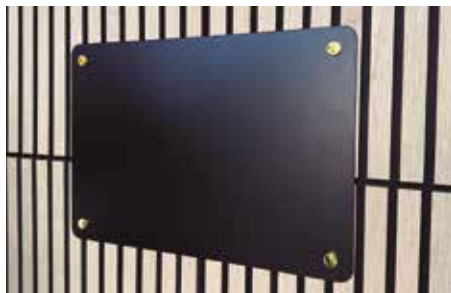

	Negro Noir Black
A x B	
35 x 50	811191

Soporte marco negro 3 un. | Support cadre noir 3 un. | Black frame support 3 un.



Ø cm	Negro Noir Black
1,6	811207

Fijación con embellecedor 2 un. | Fixation avec embellisseur 2 un. | Attachment with embellisher 2 un.



Ø cm	Negro Noir Black	Bianco Hêtre White
1,6	811481	811504

Soportes TV
Supports TV
TV Supports





EAN = 8421272 + Ref.



LCD - 1



Fijo | Fixe | Fixed





 Kg MAX. RECOM.	Kg.	 Dim. TV"	 VESA MAX. CM	 Negro Noire Black
25	0,57	13" - 29"	10 x 10	010177



LCD - 2



Giratorio e inclinable · 2 articulaciones
Orientable et basculant. 2 articulations
Turns and tilts. 2 hinges

 Kg MAX. RECOM.	Kg.	 Dim. TV"	 VESA MAX. CM	 Negro Noire Black
25	0,65	13" - 42"	20 x 20	010184



Soportes montados en fábrica | Supports assemblé en usine
 Supports comes factory assembled



Soportes TV. Gama Premiun
 Supports TV. Gamme Premium
 TV Supports. Gamme Premium

EAN = 8421272 + Ref.

LCD - 2 START



Giratorio e inclinable · 1 articulación
Orientable et basculant. 1 articulation
Turns and tilts. 1 hinges



 Kg MAX. RECOM.	Kg.	 Dim. TV"	 VESA MAX. CM	Negro Noire Black
25	0,45	13" - 29"	10 x 10	010313



LCD - 3



Giratorio e inclinable · 2 articulaciones
Orientable et basculant. 2 articulations
Turns and tilts. 2 hinges



 Kg MAX. RECOM.	Kg.	 Dim. TV"	 VESA MAX. CM	Negro Noire Black
25	0,9	13" - 42"	20 x 20	010191



ECO - 3



Giratorio e inclinable · 3 articulaciones
Orientable et basculant. 3 articulations
Turns and tilts. 3 hinges

 Kg MAX. RECOM.	Kg.	 Dim. TV"	 VESA MAX. CM	Negro Noire Black
30	2,125	13" - 65"	40 x 40	010450



Soporte universal TV
Support universel TV
TV universal support

EAN = 8421272 + Ref.

OPERA I SLIM



Fijo y ultraplano
Fixe - Ultra-plat
Fixed and ultra slim

Kg MAX. RECOM.	Kg.	Dim. TV"	VESA MAX. CM	Negro Noire Black
45	0,7	23" - 50"	20 x 40	041393



Ultraplano, el TV queda completamente adosado a la pared. Sistema universal.
Ultra-plat. La TV reste totalemente contra le mur. Système universel.
Ultra slim. The TV is completely affixed to the wall. Universal system.

OPERA II SLIM



Fijo y ultraplano
Fixe - Ultra-plat
Fixed and ultra slim

Kg MAX. RECOM.	Kg.	Dim. TV"	VESA MAX. CM	Negro Noire Black
70	1	23" - 65"	40 x 40	041409



Ultraplano, el TV queda completamente adosado a la pared. Sistema universal.
Ultra-plat. La TV reste totalemente contra le mur. Système universel.
Ultra slim. The TV is completely affixed to the wall. Universal system.

OPERA I



Inclinable
Basculant
Tilttable

Kg MAX. RECOM.	Kg.	Dim. TV"	VESA MAX. CM	Negro Noire Black
45	2,1	23" - 65"	40 x 40	010214



Este soporte se presenta montado de fábrica.
Assemblé en usine.
This support comes factory assembled.



Soporte universal TV
Support universel TV
TV universal support

EAN = 8421272 + Ref.

OPERA II



Inclinable
Basculant
Tiltable

 Kg MAX. RECOM.	Kg.	 Dim. TV"	 VESA MAX. CM	Negro Noire Black
65	2,95	23" - 84"	40 x 60	010221





Este soporte se presenta montado de fábrica.
Assembled in usine.
This support comes factory assembled.

GRAN OPERA



Inclinable · Articulable · Extensible
Basculant · Articulé · Extensible
Tiltable · Adjustable · Expandable

 Kg MAX. RECOM.	Kg.	 Dim. TV"	 VESA MAX. CM	Negro Noire Black
40	6,4	23" - 65"	40 x 40	010429





3 puntos de giro. Extensible de 11 a 43 cm. Inclinable 15°.
3 points de pivotement. Extensible de 11 a 43 cm. Basculant 15°.
3 turning points. Can be extended from 11 to 43 cm. 3 Can be tilted 15°.

SUPREME OPERA



Inclinable · Articulable · Extensible
Basculant · Articulé · Extensible
Tiltable · Adjustable · Expandable

 Kg MAX. RECOM.	Kg.	 Dim. TV"	 VESA MAX. CM	Negro Noire Black
65	7,1	23" - 84"	40 x 60	010436



3 puntos de giro. Extensible de 11 a 43 cm. Inclinable 15°.
3 points de pivotement. Extensible de 11 a 43 cm. Basculant 15°.
3 turning points. Can be extended from 11 to 43 cm. 3 Can be tilted 15°.



Soportes TV
Supports TV
TV Supports

EAN = 8421272 + Ref.

ECO AIR



Soporte para TV de techo | Support TV pour plafond
TV support for ceiling

 Kg. MAX. RECOM.	Kg.	 Dim. TV"	 VESA MAX. CM	Negro Noire Black
30	4,34	13" - 42"	20 x 20	010467



Extensible de 57 a 77 cm. Orientable 30°. Inclinaible 10°.
Extensible de 57 à 77 cm. Orientable 30°. Basculant 10°.
Can be extended from 57 to 77 cm. Pivotable from 30°. Can be tilted 10°.

Accesorios TV | Accessoires TV | TV accessories | Accessori TV

VESA



Adaptador para soportes LCD Fepre
Adaptateur pour supports LCD Fepre
Adapter supports LCD Fepre



Kg.	 VESA MAX. CM	Negro Noire Black Nero
0,24	10 x 20, 20 x 10, 15 x 15, 20 x 20	040006



GIROPLUS



1 punto de giro | 1 point de rotation
One turning point | 1 punto di svolta

Ø cm.	 Kg. MAX. RECOM.	Kg.	 Dim. TV"	Negro Noire Black Nero
30	40	0,4	14" - 17"	009355



Este soporte se presenta montado de fábrica. I Assemblé en usine.
This support comes factory assembled.

Soportes microondas
Supports micro-ondes
 Microwave brackets



EAN = 8421272 + Ref.



CARIBE



Fijo | Fixe | Fixed

 Kg MAX. RECOM. 2 UN.	Kg.	 Dim.	Blanco Blanc White	Gris Plata, Gris Argenté, Silver Grey, Grigio argénto
31,5	60	1,7	019330	019378





Dos unidades por caja.
 Deux unités a la boîte.
 Two units per box.

PANAMÁ



Extensible | Extensible | Extendable

 Kg MAX. RECOM. 2 UN.	Kg.	 Dim.	Blanco Blanc White	Gris Plata, Gris Argenté, Silver Grey, Grigio argénto
29,5 - 47	60	2,15	019316	019361



Dos unidades por caja.
 Deux unités a la boîte.
 Two units per box.

Tendederos extensibles
 Sechoirs a ligne extensibles
 Drying area extensibles

EAN = 8421272 + Ref.



ACERO | ACIER
 STEEL



Pintado Epoxi blanco. 5 varillas
 Peint époxy blanc. 5 tiges
 White epoxy painted. 5 rods

Dim. cm	Kg MAX. RECOM.		Blanco Blanc White
80		1	046909
100		1	046916
120		1	046923
140		1	046930
160		1	046947



ALUMINIO | ALUMINIUM
 ALUMINIUM



5 varillas | 5 tiges | 5 rods

Dim. cm	Kg MAX. RECOM.		Natural
80		1	046954
100		1	046961
120		1	046978
140		1	046985
160		1	046992



FRIGO CASE. Organizadores para nevera
 FRIGO CASE. Organisateur pour frigo
 FRIGO CASE. Fridge organizers

Video de instalación
 Vidéo d'installation
 Assembly video



EAN = 8421272 + Ref.



Cajón extraíble con guías | Tiroir amovible avec guides
 Removable drawer with guides

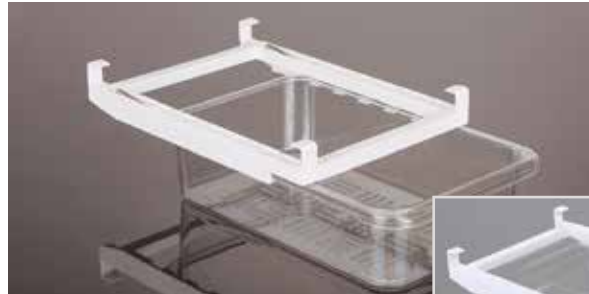

Dim. cm		5
30 x 19 x 7	016537	



Huevera | Coquetier | Egg-cup

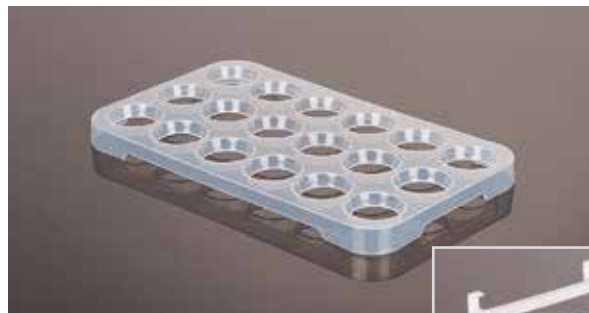

Dim. cm		5
26,5 x 15,5	016551	



Cajón extensible | Tiroir extensible
 Extendable drawer



Dim. cm		5
20/28 x 16 x 6	016544	

Puerta para pequeños animales
 Portes pour petits animaux
 Gate for small domestic animals

EAN = 8421272 + Ref.



Empotrable. 2 posiciones apertura
À encastrer. Ouverture en 2 positions
Built-in. 2 opening positions

		Blanco Blanc White Bianco	Marrón Marron Brown Marrone	Negro Noire Black Nero	Antracita Antracite Anthracite Antracite
23,5 x 21,7	18,5 x 15,8	047845	047852	047890	047906



- Gatera empotrable en puertas de madera, metal o paredes.
- 2 posiciones de apertura.
- **Atención! NO RECOMENDADA PARA CRISTAL.**
- Medida total 235 x 217. Medida del hueco 185 x 158. Medida máxima al suelo 147 mm.
- Tornillos y plantilla incluidos.
- Châtière à encastrer sur les portes en bois, en métal ou des murs.
- Ouverture en 2 positions.
- Attention, pas recommandée sur le verre.
- Dim. total 235x217. Dim. découpé. 185 x 158. Hauteur maximal au sol 147 mm.
- Vis et pochoir incluses.
- Built-in cat flap for wooden, metal doors or walls.
- 2 opening positions.
- Caution! NOT RECOMMENDED FOR GLASS
- Full size 235 x 217. Hole size 185 x 158. Maximum measurement from floor 147mm.
- Screws and stencil included.
- Built-in cat flap for wooden, metal doors or walls.



2 posiciones de apertura
2 positions d'ouverture
 2 open positions

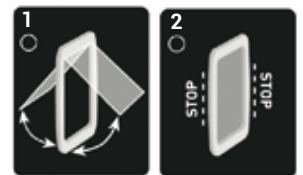

Video de instalación
 Vidéo d'installation
 Assembly video



1 Measure the door and animal.

2 Mark the door with a pencil.

3 Drill the holes for the screws.

4 Insert the mounting brackets.

5 Attach the flap to the brackets.

6 Drill the final hole for the flap.

7 Final check of the flap position.

8 Insert the flap into the door.

9 Tighten the screws to secure the flap.

A+B+C+D
 *TUNNEL EN OPTION
 TUNEL OPCIONAL
 OPTIONAL TUNNEL

* Pour portes standard de 38 mm. Para puertas estándar de 38 mm. Para portas padrão de 38 mm. For standard 38 mm doors.

Épaisseur porte	45 mm	1	Comer Central Cut
Grosor puerta	40 mm	2	
Espesura porta	35 mm	3	
Door thickness	30 mm	4	



Puerta para mascotas conectada SmartDoor
 Porte connectée pour animaux SmartDoor
 SmartDoor™ Connected Pet Door



Microchip/Electronic

<p>PetSafe - Gatera con Microchip, Puerta para Gatos, Entrada Selectiva, Acceso Automático, 4 Posiciones de Cierre, Puerta para Mascotas con microchip por RFID. Hasta 40 Mascotas Programadas PetSafe - Chatière avec puce électronique, porte pour chats. Entrée sélective, accès automatique, 4 positions de fermeture, chatière avec puce RFID. Jusqu'à 40 animaux programmés</p>	614506
<p>PetSafe - Cat Flap with Microchip, Door for Cats, Selective Entry, Automatic Access, 4 Closing Positions, Pet Door with RFID microchip. Up to 40 Scheduled Pets</p>	
<p>PetSafe Llave de Gatera con Microchip, Llavero para Puerta para Gatos, Entrada Selectiva para Gatos Sin Microchip PetSafe Clé de chatière à puce électronique, porte-clés de porte pour chat, entrée sélective pour chats sans puce électronique</p>	624710
<p>PetSafe Microchip Cat Flap Key, Cat Door Key Fob, Selective Entry for Cats Without Microchip</p>	
<p>Extensión de túnel PetSafe PAC54-16248 / Rallonge de tunnel PetSafe PAC54-16248 PetSafe Tunnel Extension PAC54-16248</p>	624888
<p>Instalador gatera microchip / Installateur microchip chat Microchip cat installer</p>	624642



Magnetic cap flap

<p>PetSafe 400SGIFD Staywell Luxus. Gatera magnética para gato, color blanco PetSafe 400SGIFD Staywell Luxus. Chatière Magnétique - Blanc</p>	002782
<p>PetSafe Imanes de Repuesto para Collar. 2 uds 932 (Art. 83245) Aimants de collier de remplacement PetSafe. 2 unités 932 (Art. 83245)</p>	008579
<p>PetSafe Staywell Deluxe - Extensión de túnel / PetSafe Staywell Deluxe - Extension du tunnel PetSafe Staywell Deluxe - Tunnel Extension</p>	002690

MÉDIDA MEDIANA
 MÉDIANE DE MESURE
 MEASUREMENT MEDIAN



Pet Door

<p>Puerta Staywell para mascotas con 2 posiciones de cierre Barrière pour animaux Staywell avec 2 positions de fermeture</p>	003802
<p>Staywell Pet Gate with 2 Closing Positions</p>	



Video de instalación
 Vidéo d'installation
 Assembly video



Más información puerta SmartDoor
 Plus d'informations sur la porte SmartDoor
 More information SmartDoor door



Tapas de registro
Trappes de visite
Revision hatch door

EAN = 8421272 + Ref.

PVC



PVC



Blanco
Blanc
White

A x B	
15 x 15	082198
20 x 20	082204
20 x 25	082211
20 x 40	082228
30 x 30	082235
30 x 40	082242



ACERO
ACIER
STEEL



NEW

Acero | Acier | Steel



Blanco
Blanc
White

A x B	
15 x 15	082280
20 x 20	082297
20 x 25	082303
20 x 30	082310
40 x 40	082334
40 x 50	082341
40 x 60	082358
50 x 50	082365
60 x 60	082372
60 x 80	082389



Ganchos acero para paneles perforados
Crochets acier pour panneaux perforés
 Steel hooks for perforated panels

EAN = 8421272 + Ref.



Ganchos rectos | Crochets droits
 Straight hooks



Dim. mm	Plata mate Argent/mat Matt Silver
100	300155
5	Juego de 4 ganchos/bolsa Lot de 4 crochets/sac Set of 4 hooks/bag



Dim. mm	Plata mate Argent/mat Matt Silver
50	300162
5	Juego de 4 ganchos/bolsa Lot de 4 crochets/sac Set of 4 hooks/bag

Kit 41 ganchos | Kit 41 crochets
 Kit 41 hooks



Dim. mm	Plata mate Argent/mat Matt Silver
100	300179
5	Juego de 41 ganchos/bolsa Lot de 41 crochets/sac Set of 41 hooks/bag

Arandelas distanciadores | Rondelles d'écartement
 Spacer washers



Dim. mm	Negro Noire Black
-	300193
5	Juego de 6 unidades/bolsa Lot de 6 unités/sac Set of 6 units/bag

Panel perforado cartón | Panneau en carton perforé
 Perforated cardboard panel

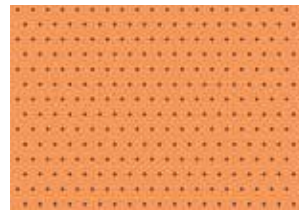

Dim. mm	Cartón Carton cardboard
60 x 90	300025
5	

Panel cartón + 41 ganchos | Panneau en carton + 41 crochets
 Cardboard panel + 41 hooks

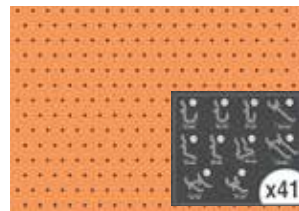

Dim. mm	Cartón Carton cardboard
60 x 90	300186
5	Juego de 41 ganchos/bolsa Lot de 41 crochets/sac Set of 41 hooks/bag

Panel perforado galvanizado
Panneau perforé galvanisé
 Galvanised perforated panel
 Pannello forato zincato

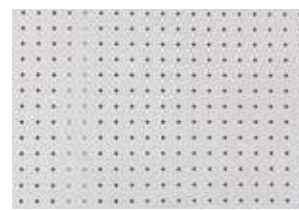

Dim. mm	Plata mate Argent/mat Matt Silver
60 x 90	300032
5	

Ganchos acero para paneles perforados
 Crochets acier pour panneaux perforés
 Steel hooks for perforated panels

EAN = 8421272 + Ref.

Gancho | Crochet | Hook



Dim. mm	Plata mate Argent mat Matt Silver
38	300049



Juego de 8 ganchos/bolsa
 Lot de 8 crochets/sac
 Set of 8 hooks/bag

Dim. mm	Plata mate Argent mat Matt Silver
25	300056



Juego de 8 ganchos/bolsa
 Lot de 8 crochets/sac
 Set of 8 hooks/bag

Dim. mm	Plata mate Argent mat Matt Silver
12	300063



Juego de 9 ganchos/bolsa
 Lot de 8 crochets/sac
 Set of 8 hooks/bag

Gancho angulo recto | Crochet à angle droit
 Right angle hook



Dim. mm	Plata mate Argent mat Matt Silver
40	300070
25	300087



Juego de 8 ganchos/bolsa
 Lot de 8 crochets/sac
 Set of 8 hooks/bag

Gancho alicates | Pince à crochets
 Hook pliers

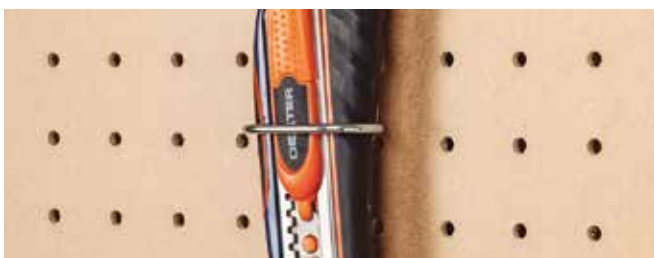

Dim. mm	Plata mate Argent mat Matt Silver
45	300094



Juego de 4 ganchos/bolsa
 Lot de 4 crochets/sac
 Set of 4 hooks/bag

Ganchos acero para paneles perforados
 Crochets acier pour panneaux perforés
 Steel hooks for perforated panels

EAN = 8421272 + Ref.

Porta llaves planas | Porte-clés plats
 Flat key holders



Dim. mm	Plata mate Argent mat Matt Silver
180	300100
5	Juego de 1 gancho/bolsa Lot de 1 crochet/sac Set of 1 hook/bag

Porta-herramientas | Porte-outils
 Tool holder



Dim. mm	Plata mate Argent mat Matt Silver
230	300117
5	Juego de 1 gancho/bolsa Lot de 1 crochet/sac Set of 1 hook/bag



Dim. mm	Plata mate Argent mat Matt Silver
230	300124
5	Juego de 1 gancho/bolsa Lot de 1 crochet/sac Set of 1 hook/bag

Ganchos dobles | Crochets doubles
 Double hooks



Dim. mm	Plata mate Argent mat Matt Silver
100	300131
5	Juego de 4 ganchos/bolsa Lot de 4 crochets/sac Set of 4 hooks/bag



Dim. mm	Plata mate Argent mat Matt Silver
50	300148
5	Juego de 4 ganchos/bolsa Lot de 4 crochets/sac Set of 4 hooks/bag

Ganchos acero multifuncionales
Crochets acier multifonctionnels
 Multifunctional steel hooks

EAN = 8421272 + Ref.

Gancho multifuncional liso
Crochet lisse multifonctionnel
 Smooth multifunctional hook



Dim. mm	Plata mate Argent mat Matt Silver
3 x 9	300315



Dim. mm	Plata mate Argent mat Matt Silver
4 x 20	300322



Gancho mural multifuncional doble tubo
Crochet multifonctionnel à double tube
 Multifunctional double tube hook



Dim. mm	Plata mate Argent mat Matt Silver
245 x 140	300230



Dim. mm	Plata mate Argent mat Matt Silver
80 x 115	300339



Gancho multifuncional pared y techo
Crochet multifonctionnel pour le mur et le plafond
 Multifunctional wall and ceiling hook



Dim. mm	Plata mate Argent mat Matt Silver
150 x 255	300247



Gancho multifuncional simple para pared
Crochet mural multifonctionnel
 Multifunctional wall hook



Dim. mm	Plata mate Argent mat Matt Silver
215 x 153	300254



Dim. mm	Plata mate Argent mat Matt Silver
300 x 250	300261



Dim. mm	Plata mate Argent mat Matt Silver
300 x 250	300278



Dim. mm	Plata mate Argent mat Matt Silver
215 x 150	300285



Dim. mm	Plata mate Argent mat Matt Silver
120 x 80	300292



Dim. mm	Plata mate Argent mat Matt Silver
140 x 115	300308



Ganchos para bicicletas
 Crochets pour bicyclettes
 Bicycle hooks

EAN = 8421272 + Ref.

Gancho bicicleta para pared y techo
 Crochet multifonctionnel pour le mur et le plafond
 Multifunctional wall and ceiling hook



Dim. mm	Plata mate Argent mat Matt Silver
150 x 150	300209



Dim. mm	Plata mate Argent mat Matt Silver
150 x 150	300216



Gancho con tornillo funda protectora
 Crochet avec vis Manchon de protection
 Hook bwith screw protective sleeve



Dim. mm	Plata mate Argent mat Matt Silver
60 x 80	300018



Porta bicicleta para pared fijo
 Porte-vélos à paroi fixe
 Fixed wall bike carrier



Dim. mm	Plata mate Argent mat Matt Silver
500 x 430 x 290	300223



Ganchos para bicicletas, patinetes y monopatines
Crochets pour vélos, trottinettes et planches à roulettes
 Hooks for bicycles, scooters and skateboards

EAN = 8421272 + Ref.



Soporte pedal | Support de pédale
 Pedal support



Dim. mm	Negro Noir Black
145 x 100 x 100	300353



Soporte pedal | Support de pédale
 Pedal support



Dim. mm	Negro Noir Black
180 x 50 x 77	300360



Soporte pared Alu | Support mural Alu
 Wall support Alu



Dim. mm	Negro Noir Black
430 x 100 x 90	300407



Soporte pared ajustable | Support mural réglable
 Adjustable wall bracket



Dim. mm	Negro Noir Black
450 x 310 x 70	300391



Ganchos para bicicletas, patinetes y monopatines
Crochets pour vélos, trottinettes et planches à roulettes
 Hooks for bicycles, scooters and skateboards

EAN = 8421272 + Ref.



Soporte rueda | Support de roue
 Wheel support

PREMIUM



Dim. mm	Negro Noir Black
265 x 118 x 95	300377



Soporte suspensión | Support de suspension
 Suspension bracket



Dim. mm	Negro Noir Black
260 x 130 x 100	300414



Soporte patinete | Support pour scooter
 Scooter stand



Dim. mm	Negro Noir Black
370 x 340 x 320	300438



Soporte monopatín | support pour skateboard
 Skateboard stand



Dim. mm	Negro Noir Black
380 x 340 x 320	300421



Protectores de vehículos
 Protection voiture
 Vehicle protectors

EAN = 8421272 + Ref.

COLUMNA EN ESQUINA
COLONNE EN ANGLE
CORNER PILAR



Con adhesivo extrafuerte
Adhésif extra fort
 With extra strong adhesive

Dim. cm		
35 x 15	1,5	039543



COLUMNA REDONDA
COLONNE RONDE
CIRCULAR PILAR



Con adhesivo extrafuerte
Adhésif extra fort
 With extra strong adhesive

Dim. cm		
30 x 38	1,5	039574



FRONTAL | FRONTAL | FRONT



Con adhesivo extrafuerte
Adhésif extra fort
 With extra strong adhesive

Dim. cm		
18 x 28	4,5	039550



Protectores de vehículos
 Protection voiture
 Vehicle protectors

EAN = 8421272 + Ref.

LATERAL | LATÉRALE | SIDE



Con adhesivo extrafuerte
Adhésif extra fort
 With extra strong adhesive

Dim. cm	cm	
36 x 8	1,5	039567



UNIVERSAL | UNIVERSEL
 UNIVERSAL



Múltiples usos. Con adhesivo extrafuerte
Usages multiples. À couper Adhésif extra fort
 Multiple use. With extra strong adhesive

Dim. cm	cm	
20 x 200	0,5	039581



SEÑAL CARGAS SALIENTES
PANNEAU CARGO SORTANT
OUTGOING CARGO SIGNAL



ABS + Reflectante homologado (V20)
ABS + Reflexant homologue (V20)
ABS + Homologated reflecting (V20)

	Dim. cm	
NORMA V20008	50 x 50	039666



Colocar obligatoriamente siempre que la carga sobresalga por la parte posterior del vehículo.
 Installation obligatoire chaque fois que le chargement dépasse par l'arrière du véhicule.
 Place obligatorily whenever the load stands out at the rear of the vehicle.

Protectores de vehículos. Calidad Profesional
 Protection voiture. Qualité professionnelle
 Vehicle protectors. Professional quality

EAN = 8421272 + Ref.

PROTECTOR ESQUINA
PROTECTEUR ANGLE
CORNER PROTECTOR



Con adhesivo extrafuerte
Adhésif extra fort
With extra strong adhesive

Dim. cm		
24 x 50	2,5	039703



PROTECTOR FRONTAL
PROTECTEUR FRONTAL
FRONT PROTECTOR



Con adhesivo extrafuerte
Adhésif extra fort
With extra strong adhesive

Dim. cm		
50 x 25	2,5	039697



Protectores de vehículos. Calidad Profesional.
 Protection voiture. Qualité professionnelle
 Vehicle protectors. Professional quality

EAN = 8421272 + Ref.

PROTECTOR COLUMNA
PROTECTEUR COLONNE
PROTECTOR CIRCULAR



Con adhesivo extrafuerte
Adhésif extra fort
With extra strong adhesive

Dim. cm		
30 x 20	1	039680



KIT 2 UN.

PROTECTOR LATERAL
PROTECTEUR LATÉRALE
SIDE PROTECTION



Con adhesivo extrafuerte
Adhésif extra fort
With extra strong adhesive

Dim. cm		
100 x 15	1	039673



KIT 2 UN.

Filtros de campana
Filtres de la hotte
 Hood filters

EAN = 8421272 + Ref.



Filtro carbon activo
Filtre à charbon actif
 Active carbon filter

Dim. cm	
47 x 57	019118



2 filtros anti grasa
2 filtres antigraisse
 2 grease filters

Dim. cm	
114 x 47	019101



1 Filtro carbón / 1 antigrasa
1 Filtre à charbon / 1 filtre à graisse
 1 Carbon filter / 1 grease filter

Dim. cm	
114 x 47	019125



Filtros de campana
Filtres de la hotte
 Hood filters

EAN = 8421272 + Ref.



Filtro antigrasa
Filtre à graisse
 Grease filter

Dim. cm	
114 x 47	019132



Filtro antigrasa+antiolor
Filtre anti-graisse + anti-odeur
 Anti-grease+ anti-odour filter

Dim. cm	
47 x 57	019149



Expositores/Implantaciones
 Expositeurs/Implantations
 Displays and In-store concessions



¡Entrega en Box Palet para una exposición atractiva y organizada en tienda!
 Livraison en Box Palet pour une exposition attrayante et organisée en magasin!
 Delivery in Box Palet for an attractive and organized exhibition in store!

Características de rollos y losetas decorativas preparados para todo tipo de reformas
 Caractéristiques des rouleaux et dalles décoratives préparées pour toutes sortes de rénovations
 Features decorative rolls and tiles prepared for all types of renovations

- Grosor del fieltro en listones y losetas de 9 mm.
- Distancia entre rollos de 15 mm.
- Fácil y rápida instalación sin herramientas.
- Fabricado en PVC 3D ultrarresistente, protegiendo la pared.
- Confort acústico.**
- Épaisseur du feutre en lamelles et en carreaux de 9 mm.
- Distance entre les rouleaux de 15 mm.
- Installation facile et rapide sans outils.
- Fabriqué en PVC 3D ultra-résistant, protégeant le mur.
- Confort acoustique.**
- Thickness of the felt in 9 mm strips and tiles.
- Rolls spacing of 15 mm.
- Easy and quick installation without tools.
- Made of ultra-resistant 3D PVC, protecting the wall.
- Acoustic comfort.**



Expositores/Implantaciones
 Expositeurs/Implantations
 Displays and In-store concessions



IMPLANTACIÓN PANELTECH ADVANCE
 IMPLANTATION PANELTECH ADVANCE
 IMPLANTACIÓN PANELTECH ADVANCE

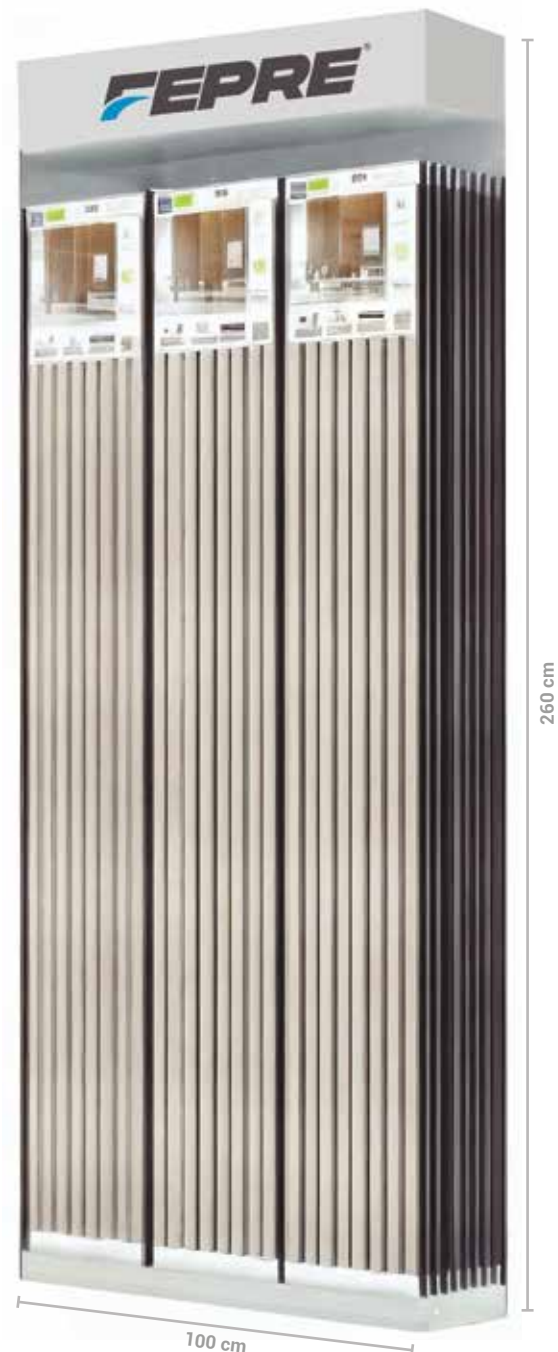

Expositores/Implantaciones
 Expositeurs/Implantations
 Displays and In-store concessions



**IMPLANTACIÓN SOPORTES
 ELECTRODOMÉSTICOS**
**IMPLANTATION SUPPORTS
 ÉLECTROMÉNAGERS**
**ELECTRICAL APPLIANCE
 SUPPORTS IMPLANTATION**

Ref. LB-1.

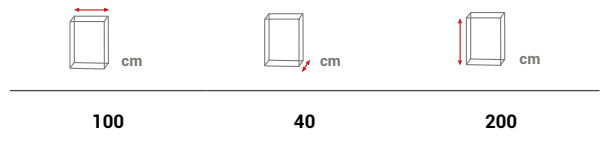

- Góndola no incluida. Cartelería incluida.
- Gondole pas compris Affiche compris.
- Stand not included. Panel included.



Expositores/Implantaciones
 Expositeurs/Implantations
 Displays and In-store concessions



**IMPLANTACIÓN SOPORTES
 ELECTRODOMÉSTICOS**
**IMPLANTATION SUPPORTS
 ÉLECTROMÉNAGERS**
**ELECTRICAL APPLIANCE
 SUPPORTS IMPLANTATION**

Ref. LB-2.

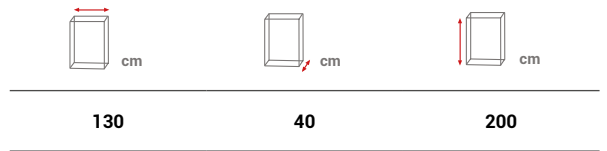

- Góndola no incluida. Cartelería incluida.
- Gondole pas compris Affiche compris.
- Stand not included. Panel included.



Expositores/Implantaciones
 Expositeurs/Implantations
 Displays and In-store concessions



IMPLANTACIÓN PROTECTORES DE VEHICULOS

IMPLANTATION PROTECTION VOITURE

VEHICLE PROTECTORS
 IMPLANTATION

Ref. LB-1.



100



40



200

- Góndola no incluida. Cartelería incluida.
- Gondole pas compris Affiche compris.
- Stand not included. Panel included.



Expositores/Implantaciones
 Expositeurs/Implantations
 Displays and In-store concessions



**IMPLANTACIÓN GANCHOS
 BICICLETAS**
**IMPLANTATION DE CROCHETS
 BICYCLETTES**
**HOOK IMPLANTATION
 BICYCLES**

Ref. LB-1.



100



40



200

- Góndola no incluida. Cartelería incluida.
- Gondole pas compris Affiche compris.
- Stand not included. Panel included.

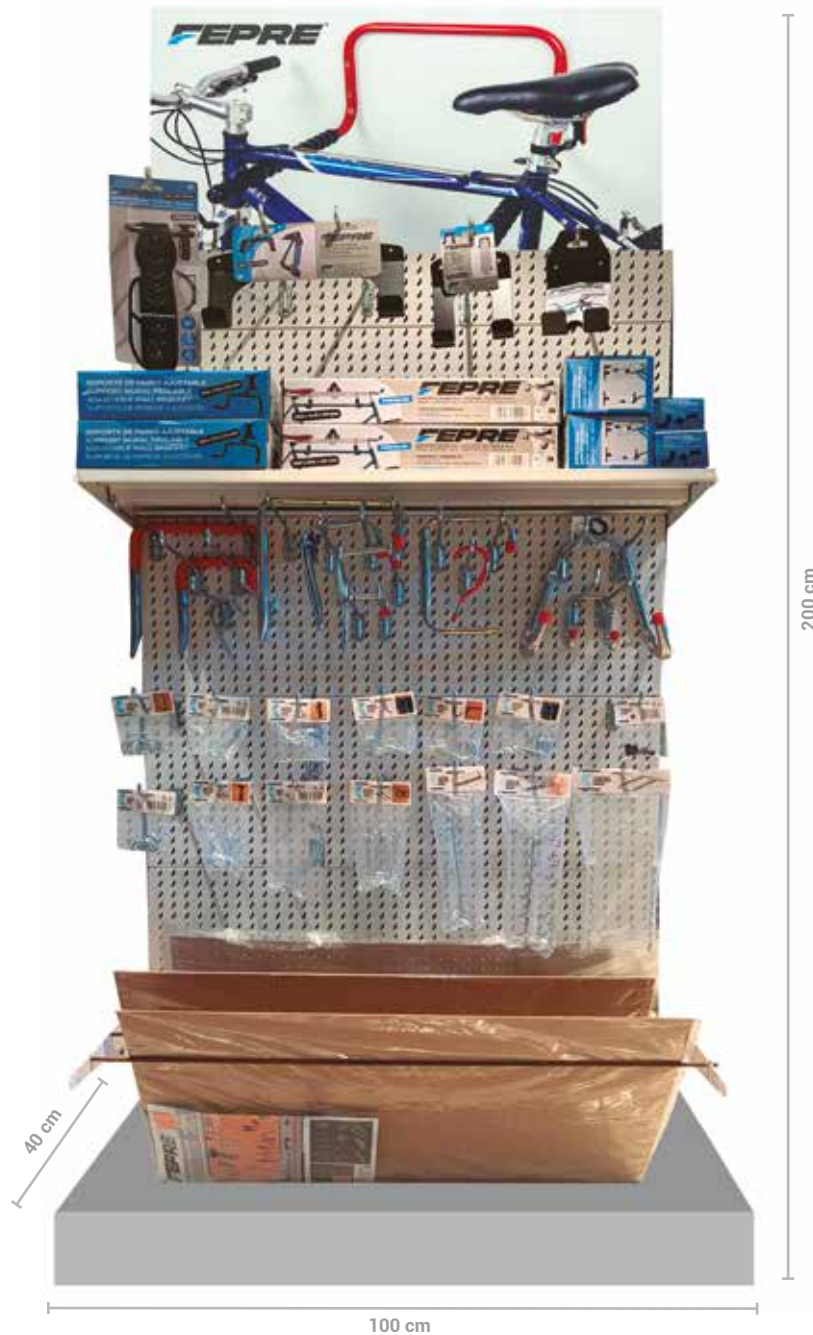

200 cm

40 cm

100 cm

 ESPAÑA**Transporte**

- No podemos aceptar pedidos inferiores a 75,00 €.
- Portes pagados y enviados por nuestros medios hasta:
 - España Peninsular: 150 € mínimo.
 - Archipiélago Balear: 300 € mínimo

Acondicionamientos

- En esta tarifa se exponen las unidades por caja / paquete / envase de cada artículo. Rogamos que adapten sus pedidos a dichas unidades de envasado con la finalidad de agilizar la preparación.
- No hay resto de pedidos.

Devoluciones

- **FEPRE** no aceptará bajo ningún concepto cualquier devolución gestionada unilateralmente por el Cliente.
- Toda devolución se deberá acordar previamente con nuestro representante/ delegado en la zona o en todo caso con nuestro Dpto. Comercial.
- **FEPRE** debe interpretar que todo bulto aceptado por nuestro Cliente está libre de rotura, salvo que se indique alguna incidencia en el albarán de transportista. Sólo así **FEPRE** podrá responsabilizar a la agencia de transportes de los daños ocasionados a la mercancía.
- Cualquier abono por devolución pactada será efectuado por **FEPRE**, descontando el valor de material en mal estado, los gastos bancarios que haya podido ocasionar, así como los logísticos.
- Para evitar problemas contables rogamos que el Cliente no se descuente el importe hasta recibir el abono por nuestra parte.

FEPRE agradece la confianza depositada en los fabricantes nacionales.

 FRANCE**Transport**

- Nous ne pouvons pas accepter les commandes inférieures à 75,00 €.
- Ports payés 300€ minimum de commande. Pour les îles, veuillez consulter les minimums de commande.

Conditionnement

- Vous trouverez sur ce tarif les unités par boîte / colis de chaque produit. S'il vous plaît, ajuster leurs ordres aux unités d'emballage afin d'accélérer la préparation.
- Pas de reliquats.

Retours

- **FEPRE** n'acceptera pas en aucun cas un retour géré unilatéralement par le Client.
- Tous les retours doivent être confirmés par notre représentant / délégué dans la région ou avec notre département commercial.
- **FEPRE** estime que chaque colis accepté par nos clients est libre de casse, à moins d'indication sur le bon de livraison du transporteur. C'est alors seulement que **FEPRE** peut demander au transporteur responsabilités pour les dommages causés.
- Dans tout abonnement pour retour de marchandise accepté, **FEPRE** déduira la valeur du matériel en mauvais état, les frais bancaires occasionnés, et aussi les frais de la logistique.
- Pour éviter les problèmes de comptabilité nous vous prions de ne pas vous déduire la valeur du retour jusqu'à ce que vous recevez notre paiement.

FEPRE remercie la confiance déposée dans les fabricants nationaux.

 REST OF THE WORLD**Transport**

- We are unable to accept orders of less than € 75,00.
- Please contact our sales department for free delivery and all exports country.

Conditioning

- Units per box/package of each article are stated along with the price. In order to speed up the assembling, we request orders be conformed to packaging units.
- No remaining orders.

Returns

- **FEPRE** will not, under any circumstances, accept returns unilaterally arranged for by the customer.
- All returns must be previously agreed with the relevant area manager or, in any case, with our Sales Department.
- All parcels accepted by the customer are understood by **FEPRE** to be undamaged unless the contrary is stated on the delivery note. This is the only way the courier will take responsibility for any damage caused during transport.
- All agreed returns will be reimbursed by **FEPRE** after deducting the amount for the damaged goods, bank charges and postage, if applicable.
- To avoid possible accounting issues, we ask our customers to not deduct any amount until a credit note issued by us is received.

FEPRE is proud to trust national manufacturers.

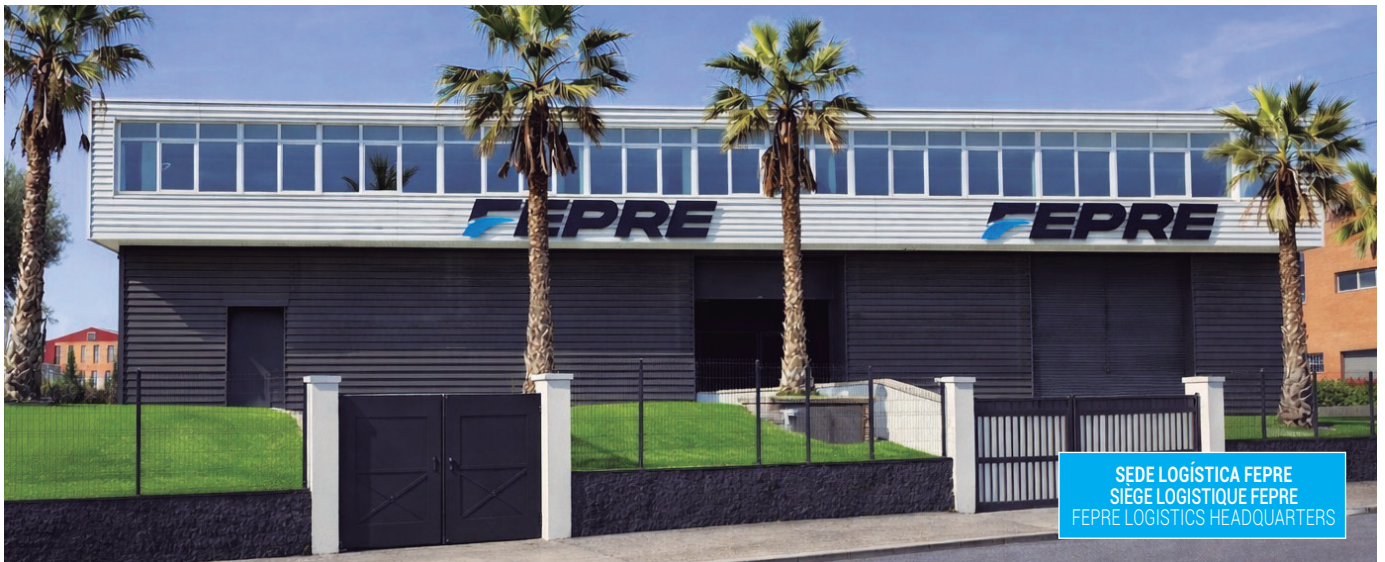

FERRETERÍA Y PRENSAS, S.A.

Polígono Ind. Can Jardí. C/ Schubert, Naves 9 a 11
Apartado de correos 91 - 08191 RUBÍ (Barcelona)
Tel: +34 93 697 01 03 - Fax: + 34 93 588 42 84
pedidos@fepre.com - atencionalcliente@fepre.com
fepre.com

